

## INSTRUCTION MANUAL

---

# **AUTO CHARGE<sup>®</sup>** **3 STEP** **AUTOMATIC BATTERY CHARGER**

MODEL # 091 - 127 - XXX - YY - (ZZZ) (WW)

XXX - 12, 24, 32, 36, 48, 72, 96, 120 and 144 VDC

YY - 8, 10, 15, 20, 27, 30, 40 and 80 Amps

ZZZ - 115VAC 60Hz, 230VAC 60Hz, 230VAC 50Hz

WW - TC, HL and UV Options

3 YEAR WARRANTY

---



**KUSSMAUL ELECTRONICS CO., INC.**

170 CHERRY AVE., WEST SAYVILLE, N.Y. 11796

TEL: in NY 631-567-0314

TOLL FREE: 800-346-0857

FAX: 631-567-5826

## **INTRODUCTION**

The Auto Charge-3 STEP CHARGER, Model 091-127-XXX-YY-(ZZZ)(WW) is a compact, completely automatic single channel battery charger designed specifically for periodic charging. Refer to **Specifications** section of this manual for Model Number Composition. Of rugged construction, the charger is made to withstand the shock and vibration encountered in vehicle mounted equipment. Utilizing components, which meet international safety standards, makes this charger ideal for worldwide applications.

## **BATTERY CHARGER FEATURES**

Completely automatic operation, charges battery on demand  
Output Voltage regulated, eliminates overcharging battery  
Output Voltage, temperature compensated (Option)  
Output, current limited to protect charger from overloading  
A 5-LED display indicating charge state and faults  
Reverse polarity protection  
Under voltage signaling (Option)  
Selectable HIGH/LOW Output Current (Option)

Refer to **Specifications** section of this manual to incorporate "Options" in Model Number Composition.

## **INSTALLATION**

The 3 STEP CHARGER should be installed in an area with adequate ventilation.  
Mount the charger using the four holes provided.  
Connect wiring from the battery to the output terminal strip.  
Double check battery wiring. Verify that the battery voltage appears at the charger output terminals (See Figure 2).

# **PRINCIPLES OF OPERATION**

A three-step lead acid battery charger operates in the three stages described below:

- 1) A discharged battery is recharged at a constant current (**bulk charge**) until its voltage reaches an overcharge level of 2.48 volts per cell. At this time the charger will switch to Finish Charge. The battery accepts 75-85% of its capacity during bulk charge.
- 2) This overcharge voltage is now maintained constant at 2.48 volts per cell (**absorption or finish charge**) until the charge current tapers down to {battery capacity/35} amperes. For the 12 volt, 80 ampere charger this current is 11.9 amperes. The battery accepts 15-25% of its capacity during absorption charge.
- 3) Once the charge current reaches the tapered down value (see above), the voltage is set to a float voltage of 2.24 volts per cell, and maintained at float charge. The battery is maintained at full charge during float charge, and the green indicator labeled "Battery Charged" is illuminated.

Figure 1 depicts the above described operation. Note that the term "absorption charge" is used interchangeably with "finish charge". Upon application of AC power, the charger is placed into bulk charge. When the charger switches to finish charge, a timer starts. In the event that the charge current did not taper down to approximately C/35 amperes after 2 ½ hours, the charger will automatically go to float charge, and a time-out will be indicated. This time-out indicator can indicate an old or leaky battery, or it can indicate that the charger is undersized for the battery being charged.

A battery fault indicator is provided to indicate the absence of a battery, a battery connected with reverse polarity, or a battery with an open circuit terminal voltage of less than 1.35 volts per cell.

# **TEMPERATURE COMPENSATION**

Temperature compensation is provided as an optional feature. A temperature probe is provided which can be placed in the air surrounding the battery or bonded to the battery case.

# **SELECTABLE OUTPUT CURRENT**

Selectable output current level is provided as an optional feature. It is normally supplied as a current output level "HIGH" and "LOW" front panel switch selectable setting. Unless otherwise specified the "HIGH" current setting refers to unit maximum output current as specified in Specifications section of this manual. The "LOW" current setting is 40% +/- 5% of the maximum current output. Consult factory for additional information on this option.

## **UNDER VOLTAGE**

Under Voltage signaling is provided as an optional feature. It is supplied as relay contact closures internal to the charger in accordance with the following specifications.

Interface Voltage and Current Rating: per NEMA Classification for AWG 18 wire and Customer Interface distance.

Consult Factory for Under Voltage "Set-Point" threshold and signal hysteresis characteristics for Under Voltage signaling equipped models. Consult Factory for field adjustment of Under Voltage Set-Point threshold.

UV RELAY: Refer to Figure 2

Energized [COM makes NO] when battery terminal voltage is **ABOVE** Under Voltage Set-Point plus signal hysteresis.

De-energized [COM makes NC] when battery terminal voltage is **EQUAL to or BELOW** Under Voltage Set-Point.

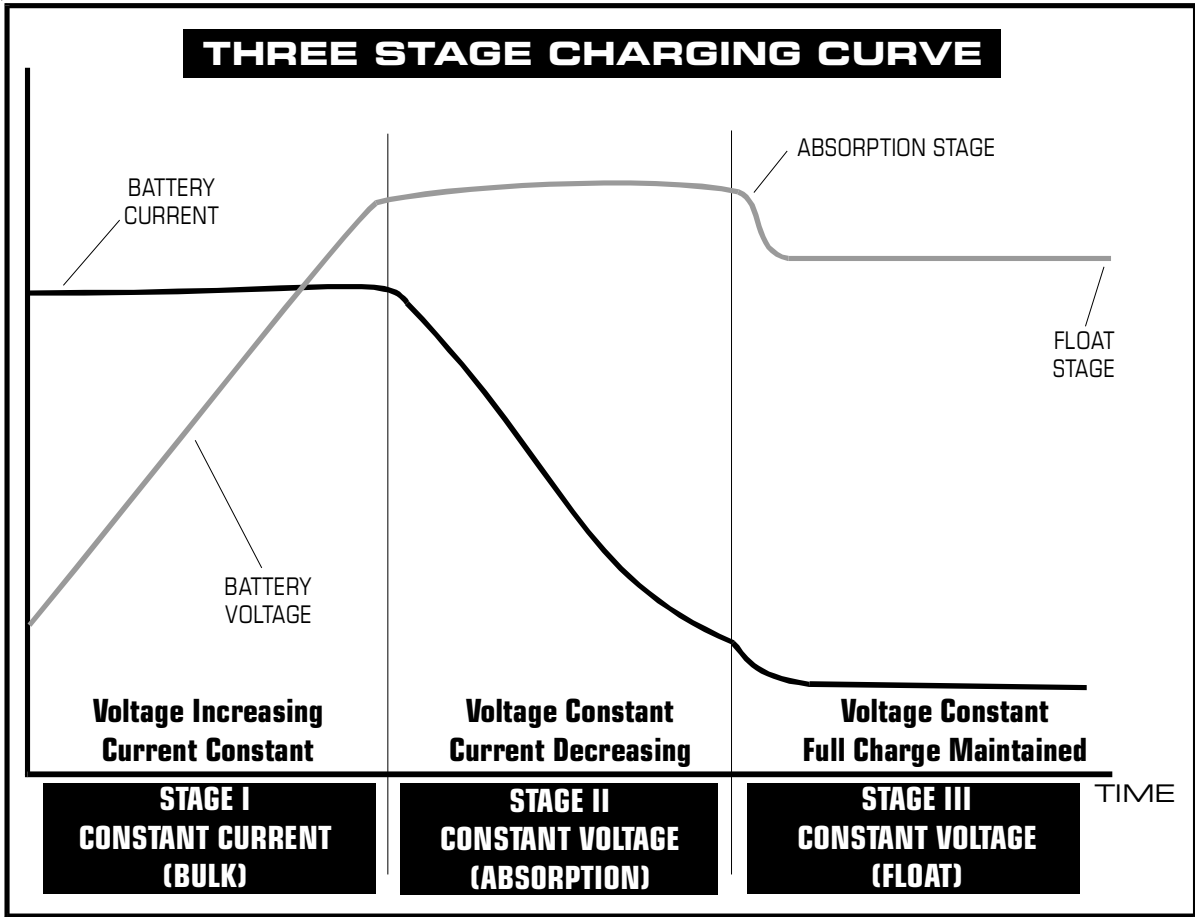

Figure 1

NOTE: This charger is designed to have its output voltage compensated for changes in Temperature. A switch on the circuit board selects whether the unit is operated in the compensated or uncompensated mode. WHEN IN THE TEMPERATURE COMPENSATED MODE THE THERMISTOR MUST BE CONNECTED. Operation without the thermistor while in the compensated mode will result in loss of voltage control and overcharging of the battery.

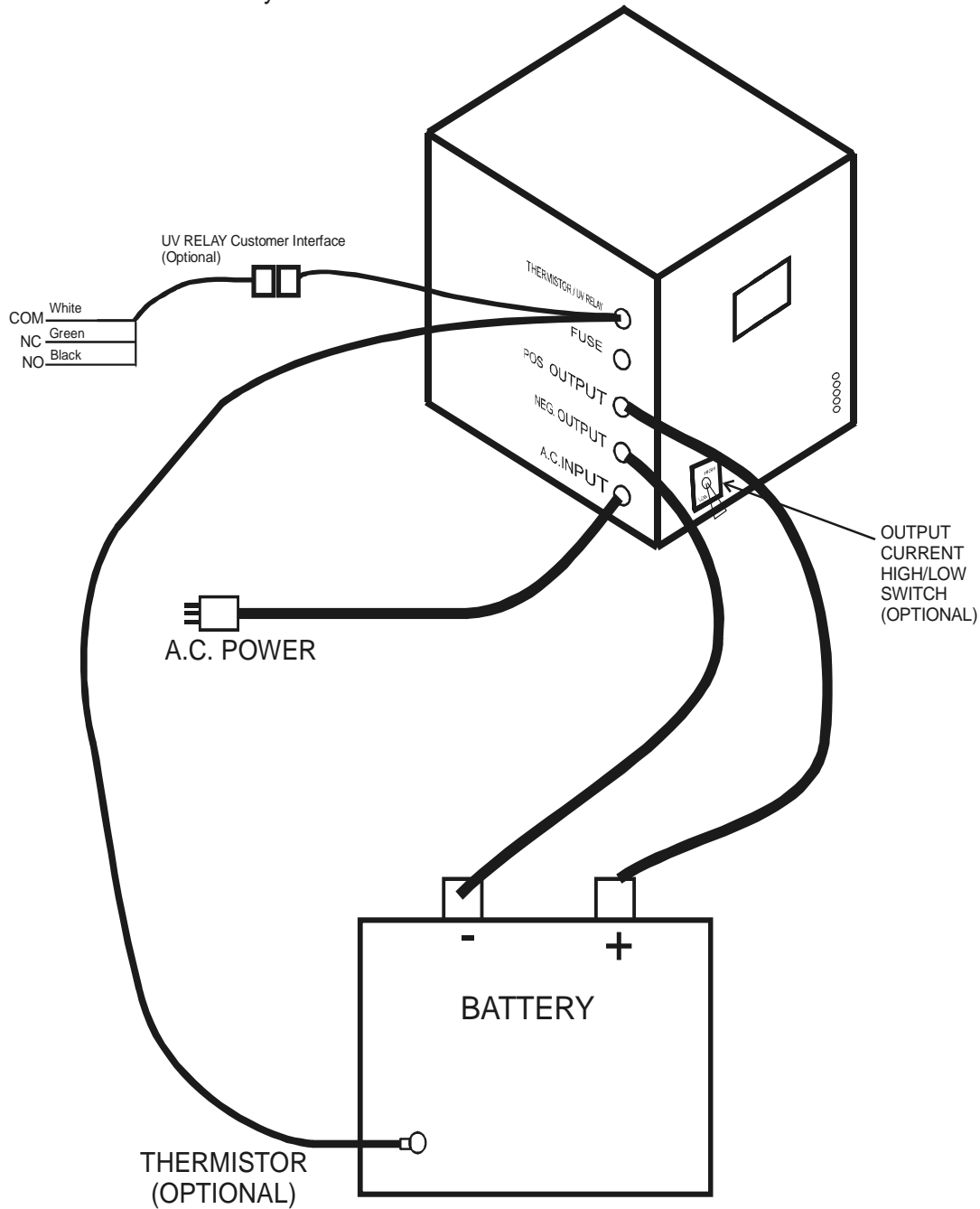

Figure 2

## INSTALLATION WIRING

# Specifications

**Input Power:& Fuse:** See Chart

**Output Power:** See Chart

**Charge Indicator:** See Chart

**Mode Indicators:** Battery Fault, Time-out, Bulk Charge, Finish Charge, and Battery Charged

**Recommended Battery Size:** See Chart

**Weight:** 65 pounds

**Temperature Compensation:** Add suffix "TC" to Model Number shown in Table below

**Output Current Select:** Add suffix "HL" to Model Number for selectable output current levels.

**Under Voltage:** Add suffix "UV" to Model Number for Under Voltage signaling option.

**Fifty (50) Hz Operation:** 230VAC input power operation only. Add "/50" as suffix to 230 in Model Number for 50Hz operation. Example: 091-127-XXX-YY-230/50.

## Model Number Composition:

091-127-XXX-YY-ZZZ-WW

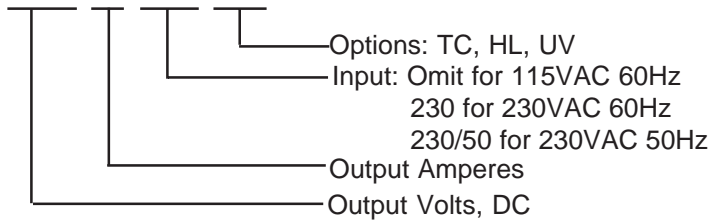

Model Number	Input Power	Input Fuse	Output	Charge	Recommended
091-127-XXX-YY	VAC, Freq., Current	Amps, Type	XXX Volts, YY Amps	Indicator	Battery Size
091-127-12-80	115 Volts 60 Hz, 20 Amps	25 Amp Slow Blow	12 Volts, 80 Amps	100 Ampere	300 to 600 ampere-hours
091-127-24-40	115 Volts 60 Hz, 20 Amps	25 Amp Slow Blow	24 Volts, 40 Amps	50 Ampere	150 to 300 ampere-hours
091-127-32-30	115 Volts 60 Hz, 20 Amps	25 Amp Slow Blow	32 Volts, 30 Amps	50 Ampere	110 to 220 ampere-hours
091-127-36-27	115 Volts 60 Hz, 20 Amps	25 Amp Slow Blow	36 Volts, 27 Amps	50 Ampere	100 to 200 ampere-hours
091-127-48-20	115 Volts 60 Hz, 20 Amps	25 Amp Slow Blow	48 Volts, 20 Amps	25 Ampere	75 to 150 ampere-hours
091-127-72-15	115 Volts 60 Hz, 20 Amps	25 Amp Slow Blow	72 Volts, 15 Amps	25 Ampere	50 to 100 ampere-hours
091-127-96-12	115 Volts 60 Hz, 20 Amps	25 Amp Slow Blow	96 Volts, 12 Amps	25 Ampere	45 to 90 ampere hours
091-127-120-10	115 Volts 60 Hz, 20 Amps	25 Amp Slow Blow	120 Volts, 10 Amps	25 Ampere	40 to 80 ampere hours
091-127-144-8	115 Volts 60 Hz, 20 Amps	25 Amp Slow Blow	144 Volts, 8 Amps	25 Ampere	40 to 80 ampere hours
091-127-12-80-230	230 Volts 60 Hz, 10 Amps	15 Amp Slow Blow	12 Volts, 80 Amps	100 Ampere	300 to 600 ampere-hours
091-127-24-40-230	230 Volts 60 Hz, 10 Amps	15 Amp Slow Blow	24 Volts, 40 Amps	50 Ampere	150 to 300 ampere-hours
091-127-32-30-230	230 Volts 60 Hz, 10 Amps	15 Amp Slow Blow	32 Volts, 30 Amps	50 Ampere	110 to 220 ampere-hours
091-127-36-27-230	230 Volts 60 Hz, 10 Amps	15 Amp Slow Blow	36 Volts, 27 Amps	50 Ampere	100 to 200 ampere-hours
091-127-48-20-230	230 Volts 60 Hz, 10 Amps	15 Amp Slow Blow	48 Volts, 20 Amps	25 Ampere	75 to 150 ampere-hours
091-127-72-15-230	230 Volts 60 Hz, 10 Amps	15 Amp Slow Blow	72 Volts, 15 Amps	25 Ampere	50 to 100 ampere-hours
091-127-96-12-230	230 Volts 60 Hz, 10 Amps	15 Amp Slow Blow	96 Volts, 12 Amps	25 Ampere	45 to 90 ampere hours
091-127-120-10-230	230 Volts 60 Hz, 10 Amps	15 Amp Slow Blow	120 Volts, 10 Amps	25 Ampere	40 to 80 ampere hours
091-127-144-8-230	230 Volts 60 Hz, 10 Amps	15 Amp Slow Blow	144 Volts, 8 Amps	25 Ampere	30 to 60 ampere hours

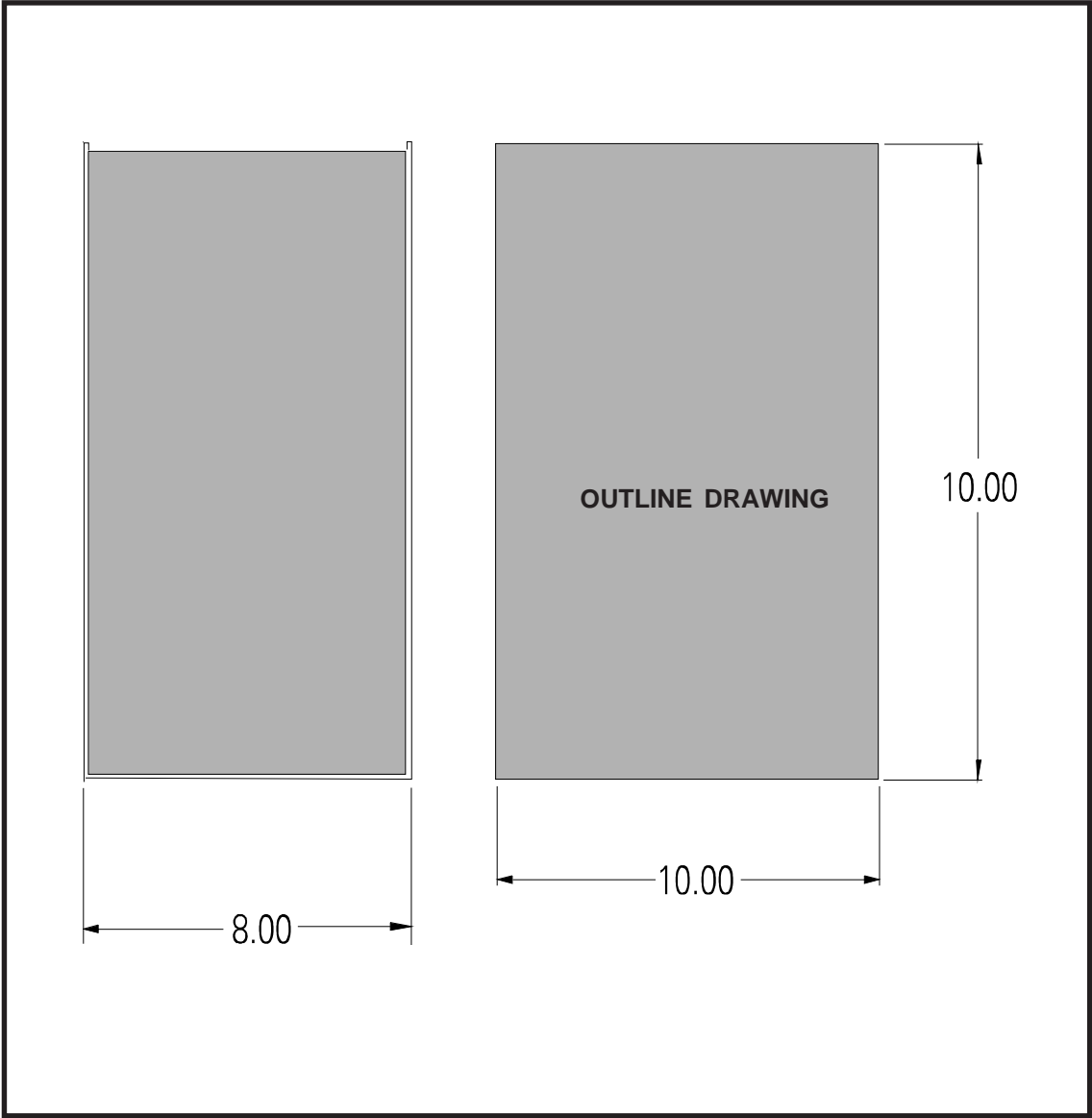



# **INSTALLATION RECORD & WARRANTY**

---

**Date Installed** \_\_\_\_\_

**Installed By** \_\_\_\_\_

**Vehicle Identification** \_\_\_\_\_

**Vehicle Owner** \_\_\_\_\_

## **WARRANTY**

All product of Kussmaul Electronics Company Inc. are warranted to be free of defects of material or workmanship. Liability is limited to repairing or replacing at our factory, without charge, any material or defects which become apparent in normal use within 3 years from the date the equipment was shipped.

Kussmaul Electronics Company, Inc. shall have no liability for damages of any kind to associated equipment arising from the installation and /or use of the Kussmaul Electronics Company, Inc. products. The purchaser, by the acceptance of the equipment, assumes all liability for any damages which may result from its installation, use or misuse, by the purchaser, his or its employees or others.