

INSTRUCTION MANUAL

AUTO ISOLATOR I

AN AUTOMATIC LOSSLESS BATTERY ISOLATOR
FOR DUAL BATTERY SYSTEMS



MODEL # 091-139-2-12

BATTERY VOLTAGE: 12 VDC
OUTPUT: 12 VOLTS, 3 AMPS

BATTERY PARALLELING SOLENOID: 200 AMPS

3 YEAR WARRANTY



KUSSMAUL ELECTRONICS CO., INC.

170 CHERRY AVE., WEST SAYVILLE, N.Y. 11796

INTRODUCTION

The Model 091-139-2-12 AUTO ISOLATOR I system is a lossless isolator replacement for the conventional diode isolator. Designed to be installed in a vehicle with one or more Main batteries that must be isolated from one or more auxiliary batteries. The system consists of a voltage detector and controller Model 091-139-CONT-12 and a separate 200-ampere rated solenoid, Model 091-139-SOL-12HO for switching the batteries. In addition to maintaining battery isolation the AUTO ISOLATOR I may parallel the batteries on engine starting if the auxiliary battery has sufficient charge to assist in the cranking. A block diagram of the system appears in figure 1.

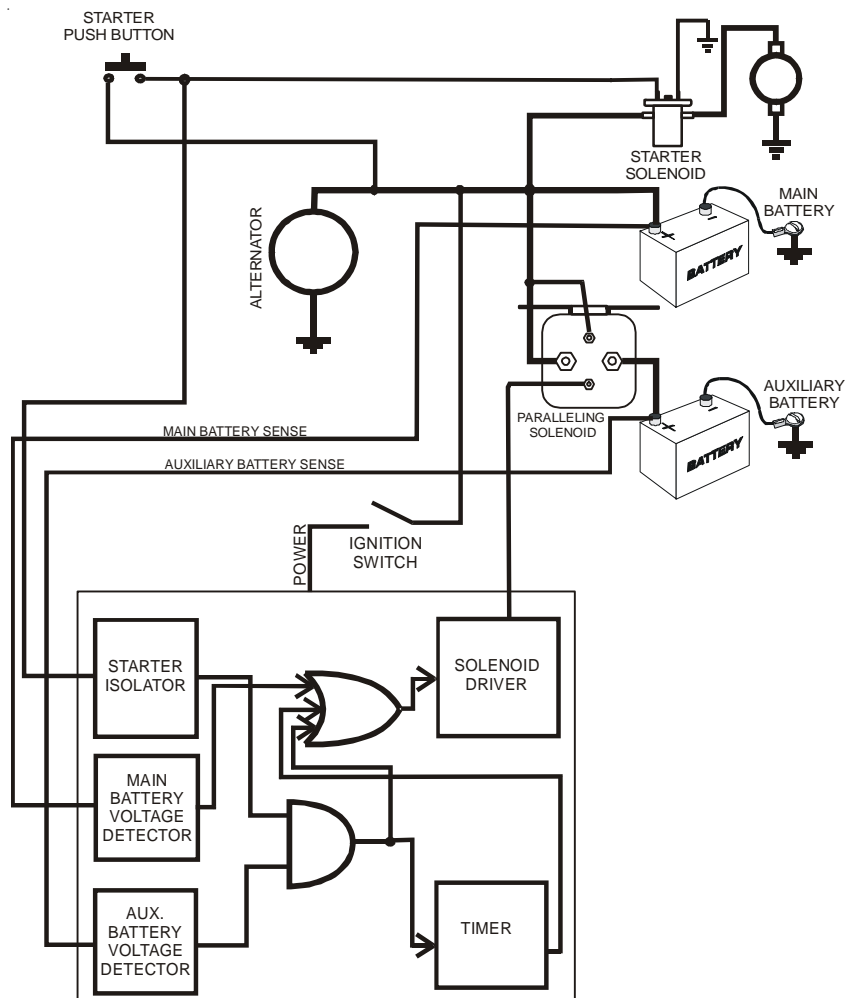

Figure 1
Block Diagram

SYSTEM OPERATION

The system receives its power from the ignition switch. With the switch "OFF" all the power is removed from the system and the solenoid is deenergized.

As soon as the operator turns the ignition "ON", the system is powered and detects the voltage of the main and auxiliary batteries. If the auxiliary battery voltage is 12.4 volts or greater, (indicating sufficient charge) cranking the engine will cause the paralleling solenoid to be energized. A 10-second timer will maintain the paralleling solenoid if the engine doesn't start immediately and must be cranked a second time. When the engine starts the alternator output raises the battery voltage. This increase in voltage is detected and the paralleling solenoid is held energized charging both batteries.

If when the engine is started the auxiliary battery voltage is below 12.0 volts the paralleling solenoid is not energized while cranking. As soon as the engine starts, the alternator raises the main battery voltage and the solenoid is energized charging both batteries.

Upon engine shutdown the ignition switch is placed in the "OFF" position. Power is removed from the Auto Isolator and the solenoid is deenergized.

INSTALLATION

Install the 091-139-CONT-12 Controller in a suitable location protected from the weather and engine heat. The 091-139-SOL-12HO Solenoid may be mounted in the engine compartment or at a location to minimize the length of the battery cables. Install wiring per figure 2.

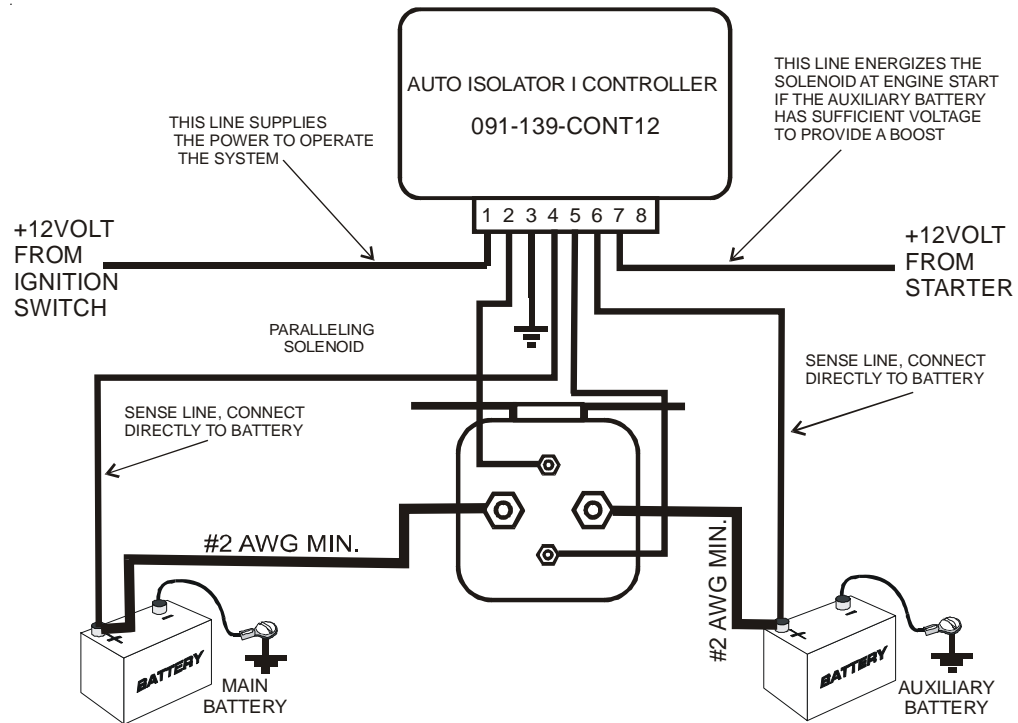

ALL WIRES #16 AWG EXCEPT AS NOTED

Figure 2

AUTO ISOLATOR I
Model 091-139-12

INSTALLATION WIRING

CALIBRATION

The voltage setpoints may be altered in the field to suit particular customer requirements. Adjustments are provided to adjust the main battery voltage at which the paralleling solenoid is energized. An additional adjustment permits adjusting the voltage below which the auxiliary battery will not be paralleled for starting boost.

CW INCREASES VOLTAGE

AUXILIARY BATTERY VOLTAGE ADJUST

MAIN BATTERY VOLTAGE ADJUST

INDICATOR ILLUMINATED WHEN MAIN BATTERY VOLTAGE IS ABOVE SETPOINT 13.3 VOLTS

INDICATOR ILLUMINATED WHEN AUXILIARY BATTERY VOLTAGE IS ABOVE SETPOINT, 12.0 VOLTS

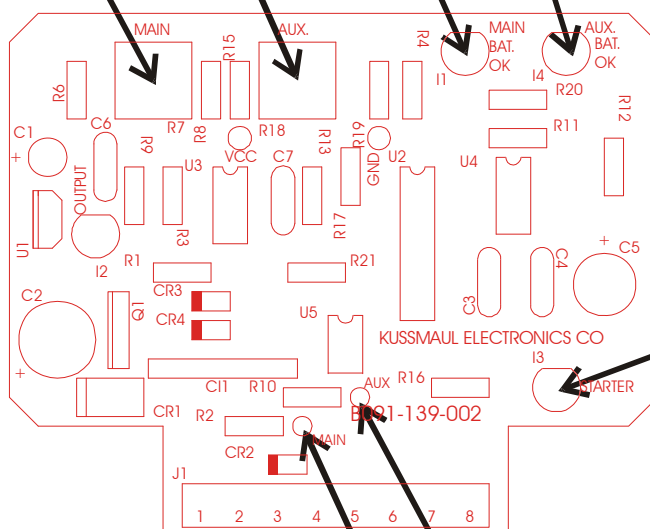

ILLUMINATES DURING ENGINE CRANKING

MEASURE AUX. BAT. VOLTAGE HERE

MEASURE MAIN BAT. VOLTAGE HERE

Figure 3

VOLTAGE ADJUSTMENTS AUTO ISOLATOR 1

SPECIFICATION AND OUTLINE

CONTROLLER, Model 091-139-CONT12

Volts to parallel: 13.3 volts, field adjustable

Battery load: .000125 amps.

Output current: 3 amps

Weight: .4 lbs.

SOLENOID, Model 091-139-SOL-12HO

Volts: 12 volts D.C.

Coil current: .65 amps

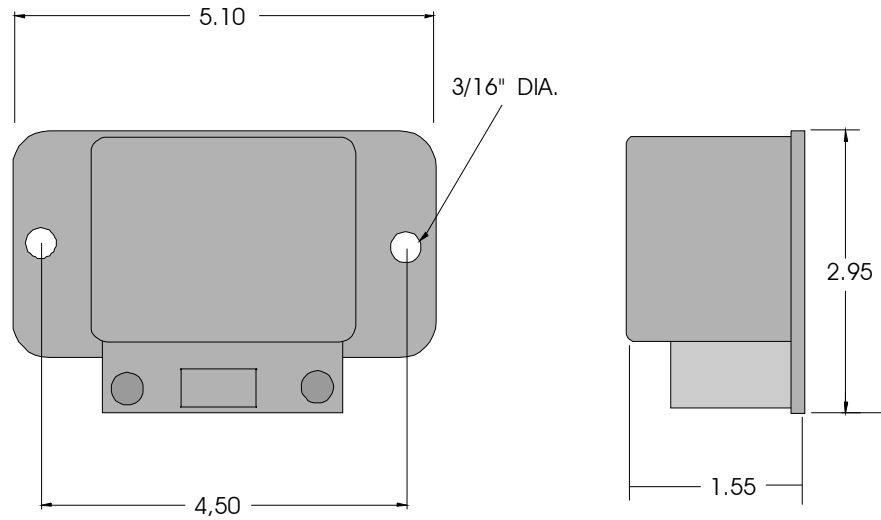

OUTLINE, AUTO ISOLATOR I CONTROLLER, 091-139-CONT12

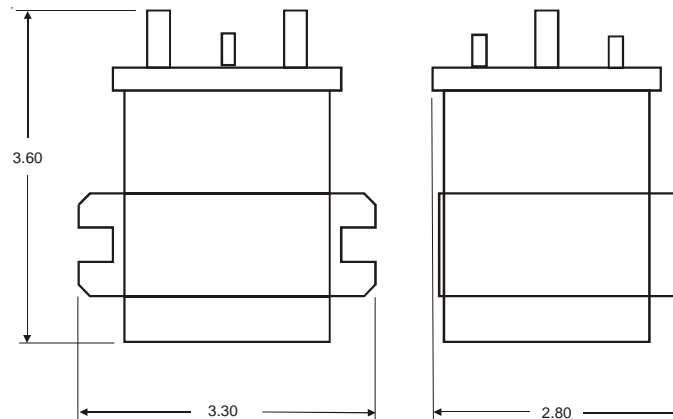

OUTLINE, AUTO ISOLATOR I SOLENOID, 091-139-SOL-12HO

INSTALLATION RECORD & WARRANTY

Date Installed _____

Installed By _____

Vehicle Identification _____

Vehicle Owner _____

WARRANTY

All product of Kussmaul Electronics Company Inc. are warranted to be free of defects of material or workmanship. Liability is limited to repairing or replacing at our factory, without charge, any material or defects which become apparent in normal use within 3 years from the date the equipment was shipped.

Kussmaul Electronics Company, Inc. shall have no liability for damages of any kind to associated equipment arising from the installation and /or use of the Kussmaul Electronics Company, Inc. products. The purchaser, by the acceptance of the equipment, assumes all liability for any damages which may result from its installation, use or misuse, by the purchaser, his or its employees others.