

INSTRUCTION MANUAL

SUPER 30 AUTO EJECT

AUTOMATIC SHORE LINE DISCONNECT



30 AMP
MODEL # 091-159-XXX

2 YEAR WARRANTY



KUSSMAUL ELECTRONICS CO., INC.

170 CHERRY AVE., WEST SAYVILLE, N.Y. 11796

TEL: 631-567-0314

TOLL FREE: 800-346-0857

FAX: 631-567-5826

WEB: www.kussmaul.com E-MAIL: sales@kussmaul.com

INTRODUCTION

The Super 30 Auto Eject is a completely sealed automatic power line disconnect. This prevents contamination of the mechanism by road dirt and ensures long reliable life even when mounted in the most severe environment. A novel plug detector closes and opens the 120 volt A.C. circuit after the mating connector is inserted and before the connector is ejected. This eliminates arcing at the connector contacts and assures long contact life. As with all Auto Ejects, the Super 30 Auto Eject is connected to the starter circuit so that ejection occurs when the engine is cranked.

INSTALLATION INSTRUCTIONS

Step #1 Wiring Unit

1. Remove rear plastic cover from Super 30 Auto Eject by unscrewing (4) #8-32 screws.
2. See Figure 3, DC wiring. Snake wires through small cover strain relief and install wires as shown use 18 AWG wire minimum.
3. See Figure 2, AC wiring. Snake wires through large cover strain relief and install wires as shown use 10 AWG wire minimum.
4. Re-install rear plastic cover.
5. Test the unit to see if it is operational before mounting.

Step #2 Mounting of Unit

1. Locate a convenient place on the vehicle to mount the AUTO EJECT. A minimum clearance of 5 inches behind the mounting panel is required.
2. Place the Hole Template (Figure 4) in position and center punch in 6 places.
3. Drill 6 mounting holes, #29 drill (0.136" diameter). Be certain that all the holes are precisely located.
4. Cut-out rectangular hole.
5. See Figure 1, Mounting. Install Weatherproof Cover, Weatherproof Cover Gasket, Mounting Plate, and Mounting Plate Gasket to super 30 using (2)#8-32 x 3/4" and (2)#8-32 x 1 5/8" screws provided.
6. Install that assembly into cut-out in truck wall using (6)#8-32 x 1/2" self tapping screws provided.

TEST AND OPERATION

To test the unit make sure all wiring is complete. Plug in connector to the Super 30 Auto Eject and start the vehicle. The connector should eject at this time.

The Super 30 Auto Eject disconnects the shoreline by extending a shaft to push the plug out of the unit.

A novel plug detector closes and opens the 120-volt A.C. Circuit after the mating connector is inserted and before the connector is ejected. This eliminates arcing at the connector contacts and assures long contact life. Because of this, the connector can be operated manually or automatically with no damage to the unit.

NOTES AND CAUTIONS

NOTE

Do not permit the shore line to drop to the floor when it is ejected. Keep from falling by utilizing a bungee cord restraint, cord reel or some other device. Dropping the connector may result in damage or breakage. Kusmaul Electronics Co., Inc. does not Warrant the connector.

ABOUT CONNECTORS

The Super 30 Auto Eject is supplied with mating connector. We suggest that you utilize the connector supplied. When replacing with another connector, test carefully that the new connector will eject properly.

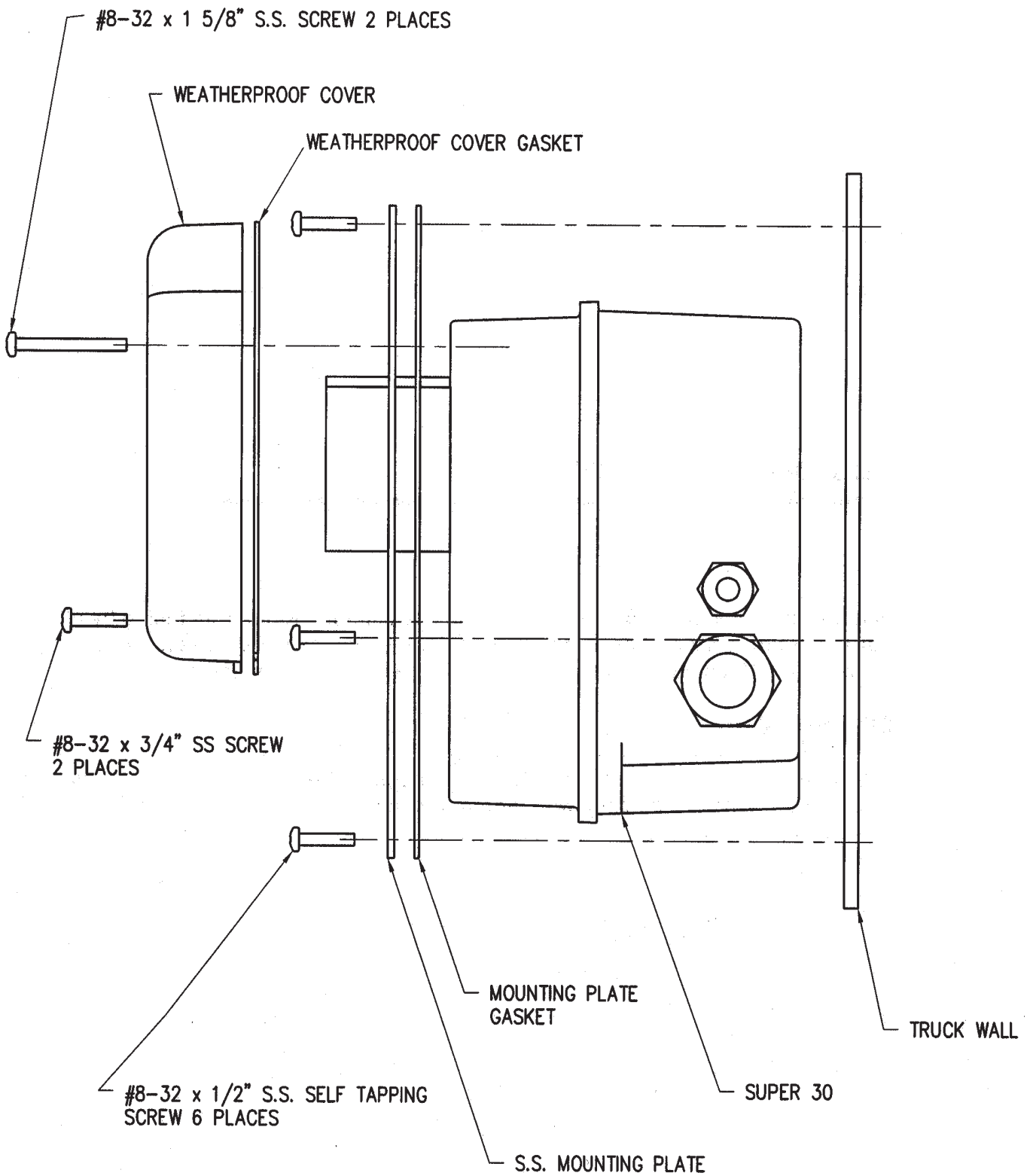

UNLESS OTHERWISE SPECIFIED:
 DIMENSIONS ARE IN INCHES
 TOLERANCES
 DECIMALS ANGULAR
 .XX ± .005
 .XXX ± .010
 DO NOT SCALE DRAWING



KUSSMAUL ELECTRONICS CO., INC.
 WEST SAYVILLE, NY

FIGURE 1 MOUNTING INSTRUCTIONS

DRAWN
T. Nugent

FINISH

MAT

SIZE	DWG NO.	REV
	091-159	
SCALE	DATE	SHEET OF

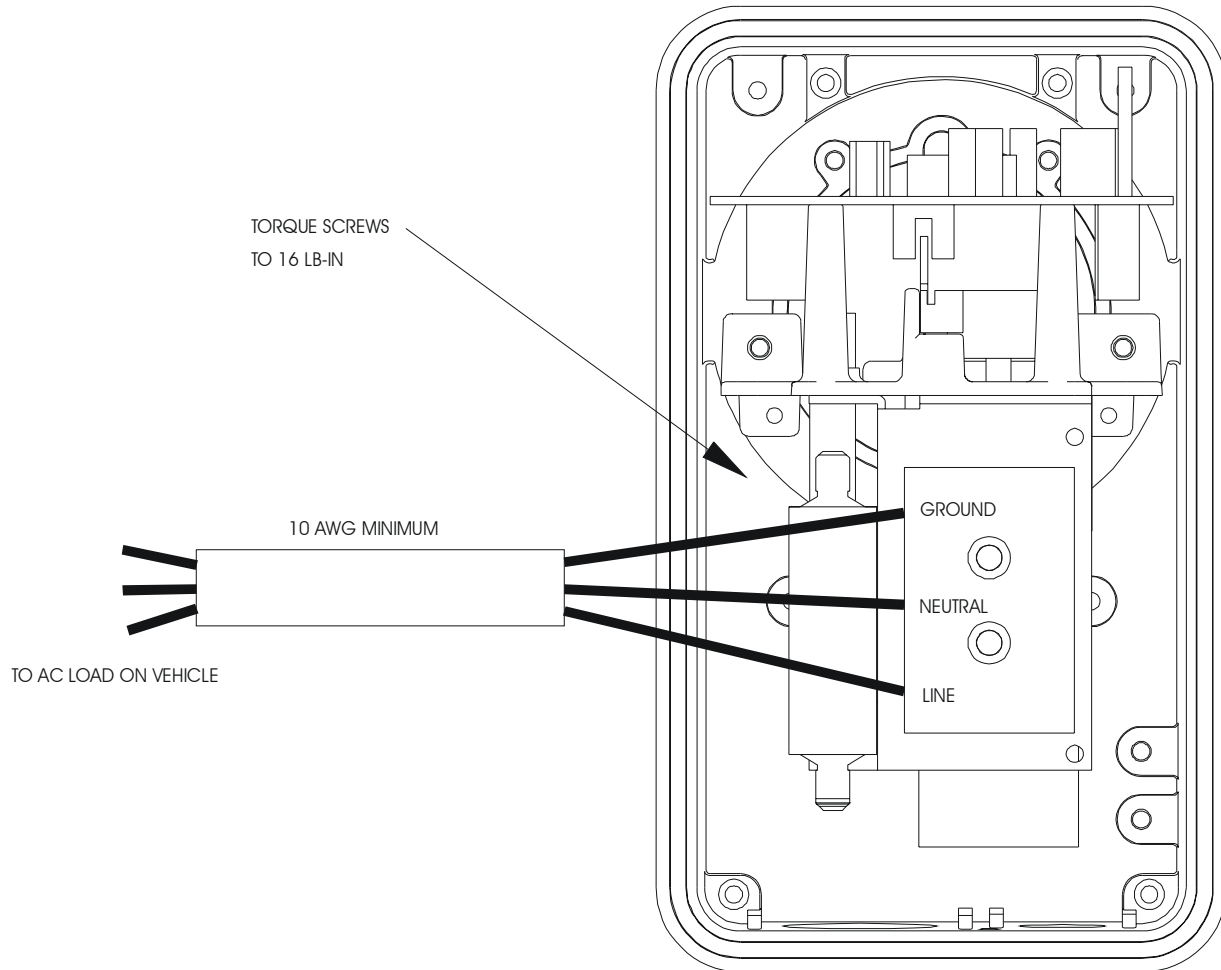

BACK OF SUPER 30 AUTO EJECT
WITH REAR PLASTIC COVER REMOVED

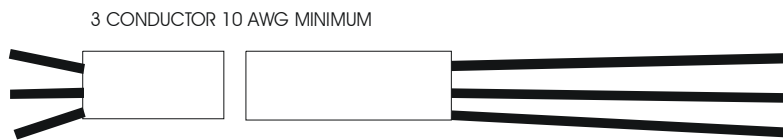

UNLESS OTHERWISE SPECIFIED: DIMENSIONS ARE IN INCHES TOLERANCES		 KUSSMAUL ELECTRONICS CO., INC. WEST SAUVILLE, NY		
DECIMALS	ANGULAR			
.XX	+ .005	FIGURE 2 AC WIRING		
.XXX	+ .001			
DO NOT SCALE DRAWING		SIZE	DWG NO. 091-159	REV
DRAWN	T. Nugent	SCALE		DATE
FINISH		SHEET		OF
MAT:				

NOTE: FUSE
 3 AMP FUSE FOR 12 VOLT
 2 AMP FUSE FOR 24 VOLT

CONNECTOR ON PC BOARD

+ 12 VOLTS
 CONTINUOUS

GROUND

TO STARTER

3 CONDUCTOR 18 AWG WIRE

PC BOARD

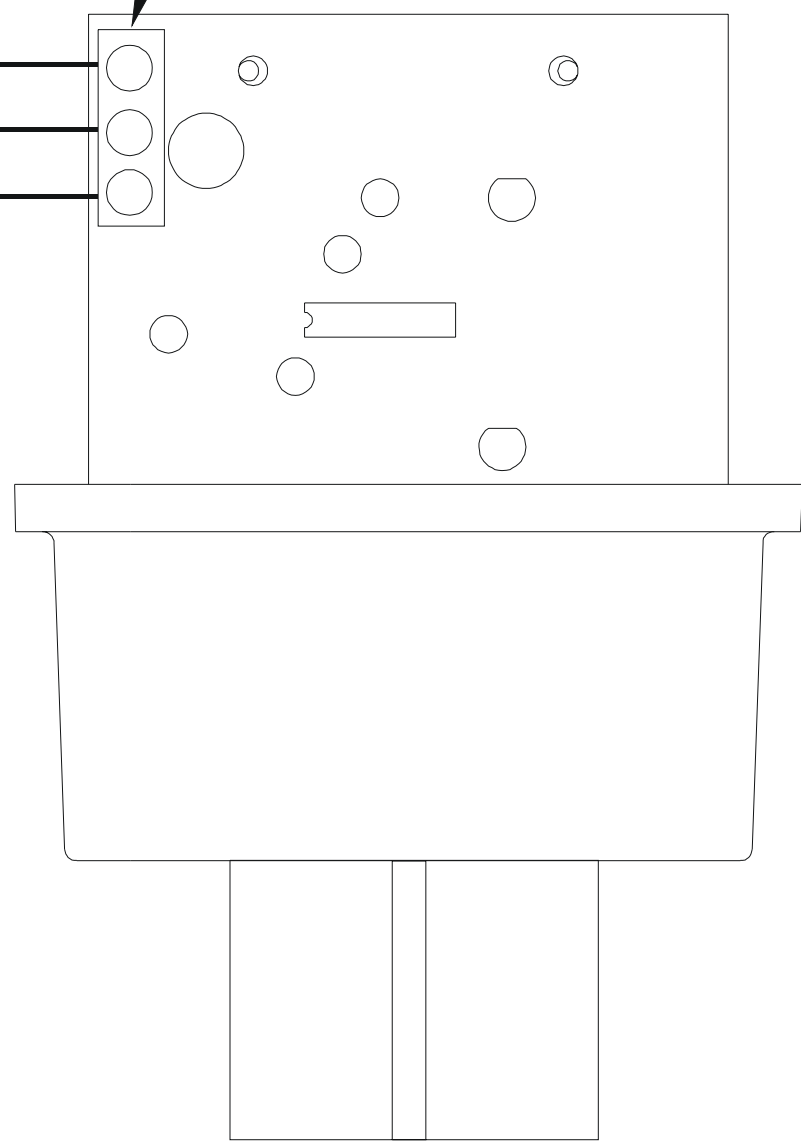

TOP OF SUPER 30 AUTO EJECT
 WITH REAR PLASTIC COVER REMOVED

UNLESS OTHERWISE SPECIFIED: DIMENSIONS ARE IN INCHES TOLERANCES		 KUSSMAUL ELECTRONICS CO., INC. WEST SAVILLE, NY	
DECIMALS	ANGULAR		
.XX	+ .005	FIGURE 3 DC WIRING	
.XXX	+ .001		
DO NOT SCALE DRAWING		DRAWN: T. Nugent	
FINISH:		SIZE:	DWG NO. 091-159
MAT:		SCALE:	DATE:
		SHEET	OF

PLUG WIRING

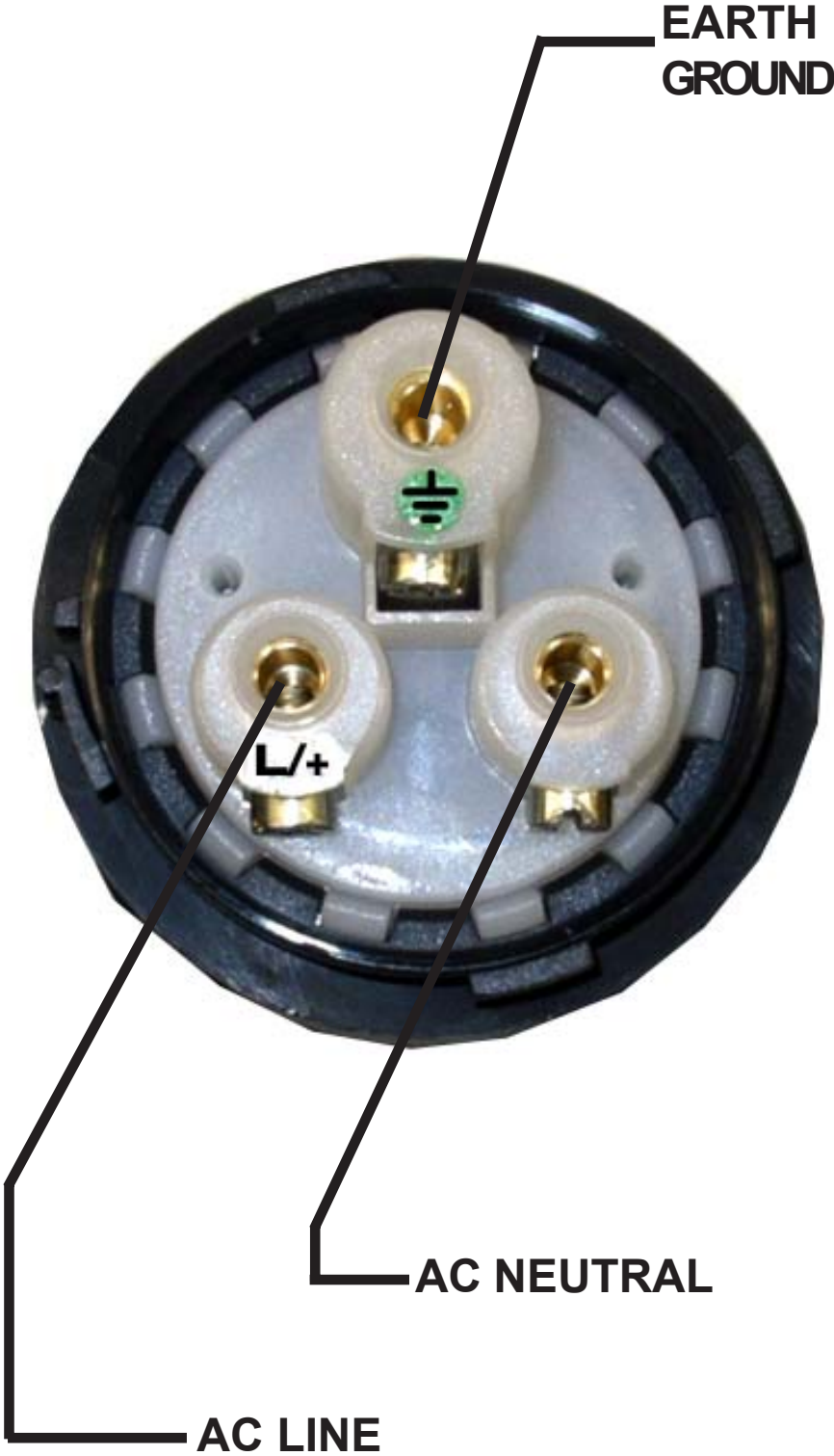

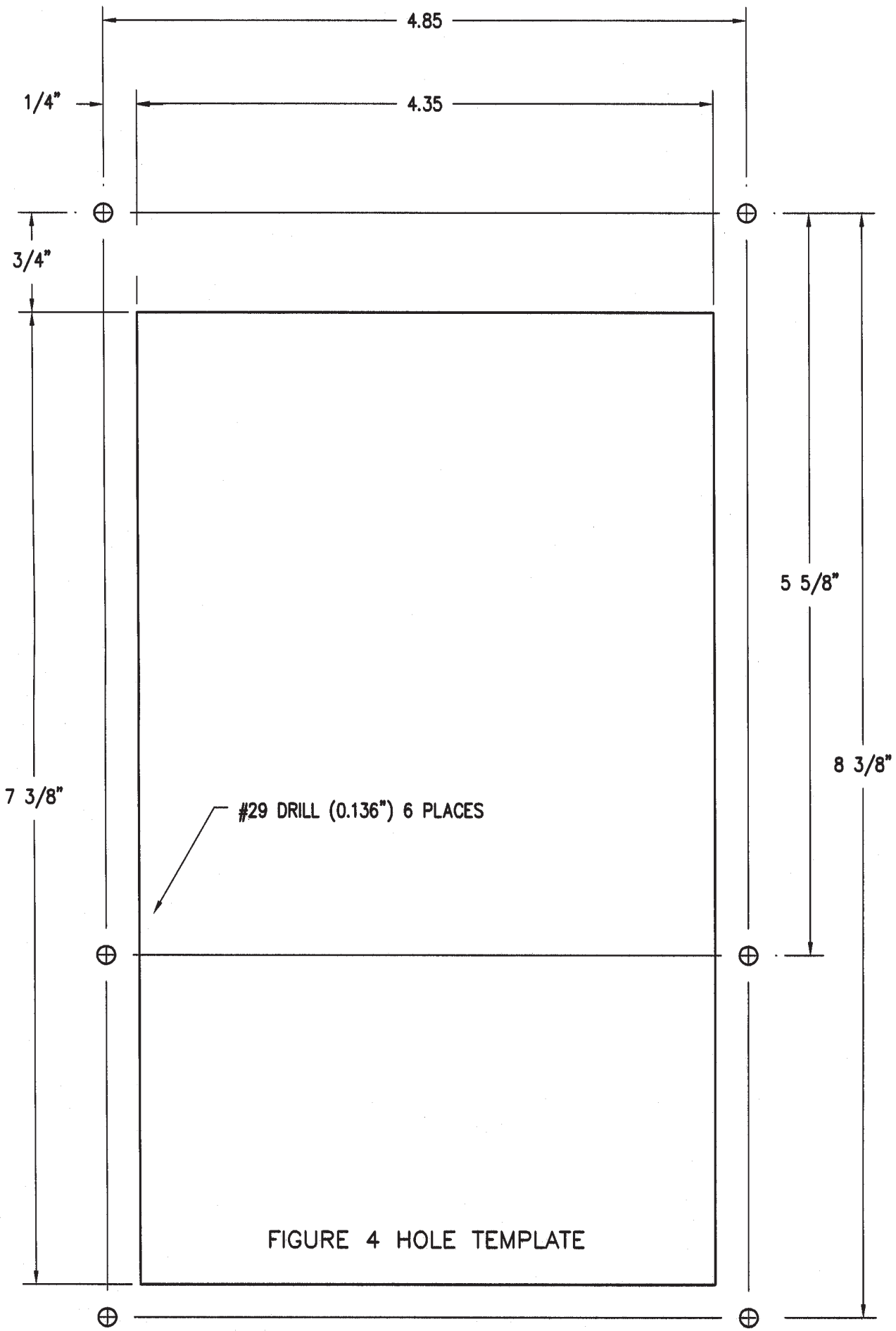

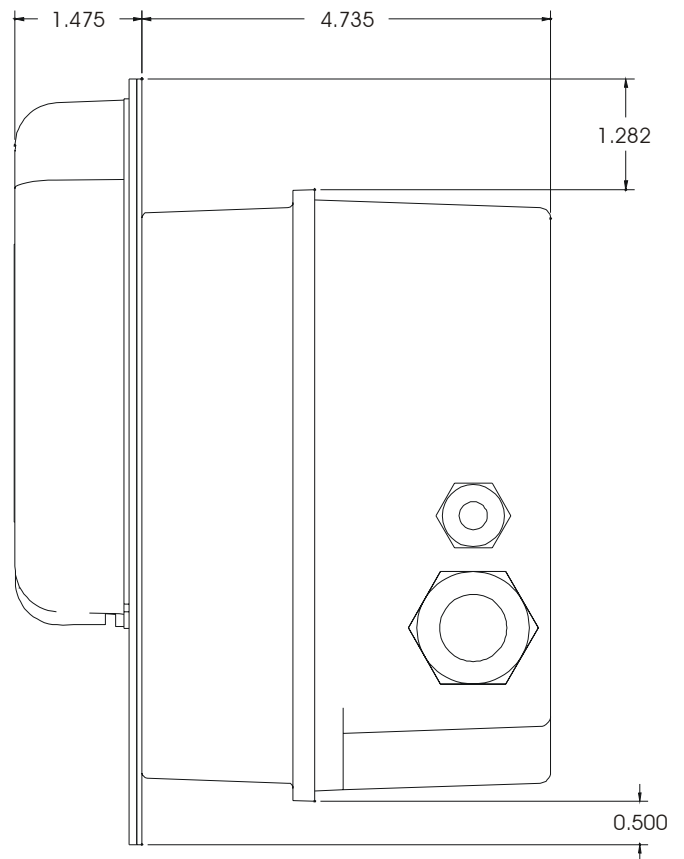
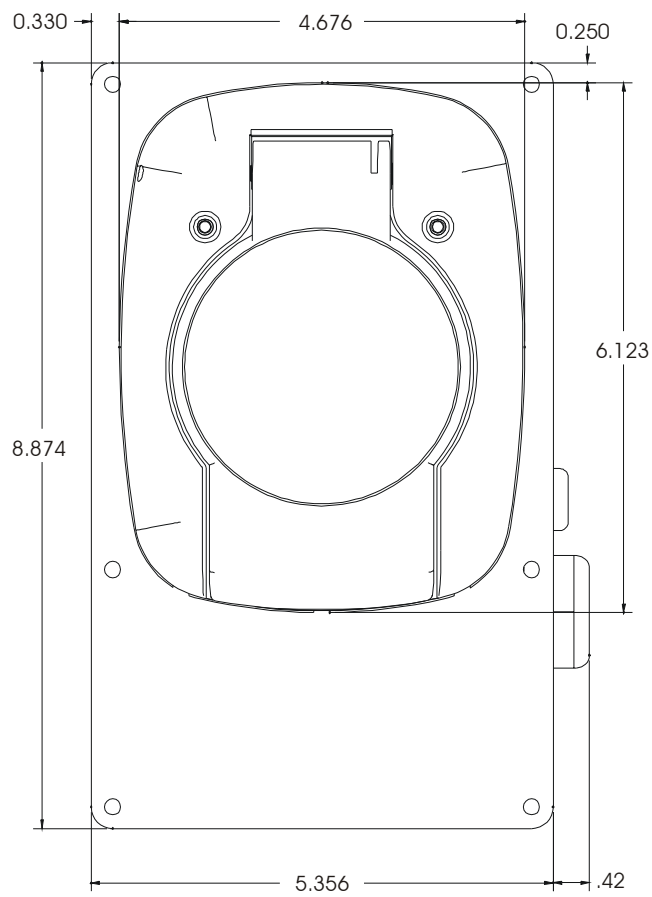
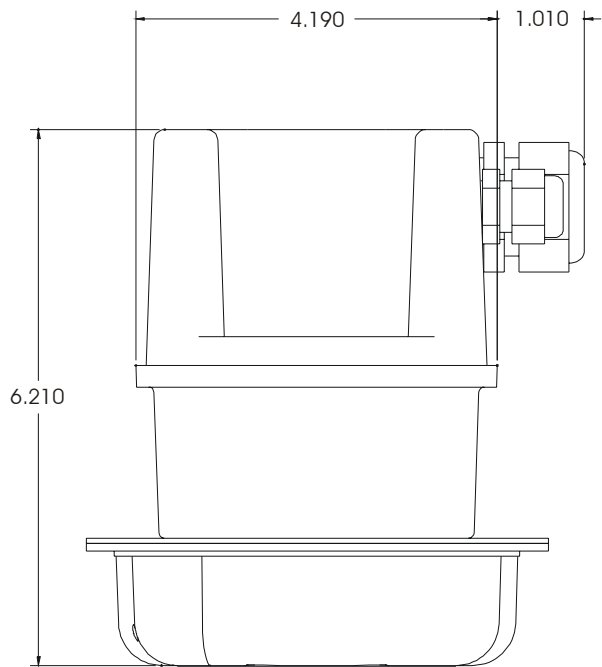

UNLESS OTHERWISE SPECIFIED:
 DIMENSIONS ARE IN INCHES
 TOLERANCES
 DECIMALS ANGULAR
 .XX + .005
 .XXX + .001
 DO NOT SCALE DRAWING



KUSSMAUL ELECTRONICS CO., INC.
 WEST SAVILLE, NY

OUTLINE DRAWING

DRAWN T. Nugent	SIZE	DWG NO. 091-159	REV
FINISH	SCALE	DATE	SHEET OF
MAT.			

INSTALLATION RECORD & WARRANTY

Date Installed _____

Installed By _____

Vehicle Identification _____

Vehicle Owner _____

2 YEAR WARRANTY

All Super 30 Auto Ejects manufactured by Kussmaul Electronics Company Inc. are warranted to be free of defects of material or workmanship. Liability is limited to repairing or replacing at our factory, without charge, any material or defects which become apparent in normal use within 2 years from the date the equipment was shipped. Equipment is to be returned, shipping charges prepaid and will be returned, after repair, shipping charges paid.

This warranty does not include normal wear and tear, pitting of the electrical contacts, malfunction due to contamination of the mechanism, or any cracking, breakage or damage to the connector.

Kussmaul Electronics Company, Inc. shall have no liability for damages of any kind to associated equipment arising from the installation and /or use of the Kussmaul Electronics Company, Inc. products. The purchaser, by the acceptance of the equipment, assumes all liability for any damages which may result from its installation, use or misuse, by the purchaser, his or its employees or others.