

## INSTRUCTION MANUAL

---

# AUTO CHARGE 12HO AUTOMATIC BATTERY CHARGER



**MODEL # 091-170-XX**

**NOTE :**  
This charger is designed for  
vehicles with a single  
battery system

**3 YEAR WARRANTY**



**KUSSMAUL ELECTRONICS CO., INC.**

170 CHERRY AVE., WEST SAYVILLE, N.Y. 11796

# **INTRODUCTION**

---

The Auto Charge 12HO is Battery Charger is a compact completely automatic charger designed for installation on vehicles with a single battery system. The voltage of the battery connected to the Auto charger 12HO is sensed via the charging cables so that the battery is charged according to its requirements. An ammeter provides continuous indication of the charger output.

Construction of the Auto Charge 12HO is extremely rugged to withstand the shock and vibration normally encountered by vehicle mounted equipment. The unit operates completely automatically and stops charging the batteries when they are fully charged. There is no trickle charge and therefore no danger of overcharging and water boil-off. Any parasitic loads on the battery such as radio, lights, etc., are automatically supplied with current by the charger.

# **INSTALLATION**

---

The Auto Charge 12HO Automatic Battery Charger should be installed in an area with adequate ventilation. A power terminal is supplied for connection to AC.

1. Mount the charger using the four holes located in the front and rear of the charger.
2. Connect the wiring from the battery to the Output Terminal Strip. Spade lugs that have been securely crimped, or soldered, should be used.
3. Double check all wiring before proceeding.
5. Wire the A.C. power line cord.
6. Pilot light will light to show that the charger has power.

# INSTALLATION WIRING DIAGRAM

Optional Bar-graph Indicator  
091-39-022

**CAUTION:** DISCONNECT SUPPLY  
BEFORE FUSE SERVICE

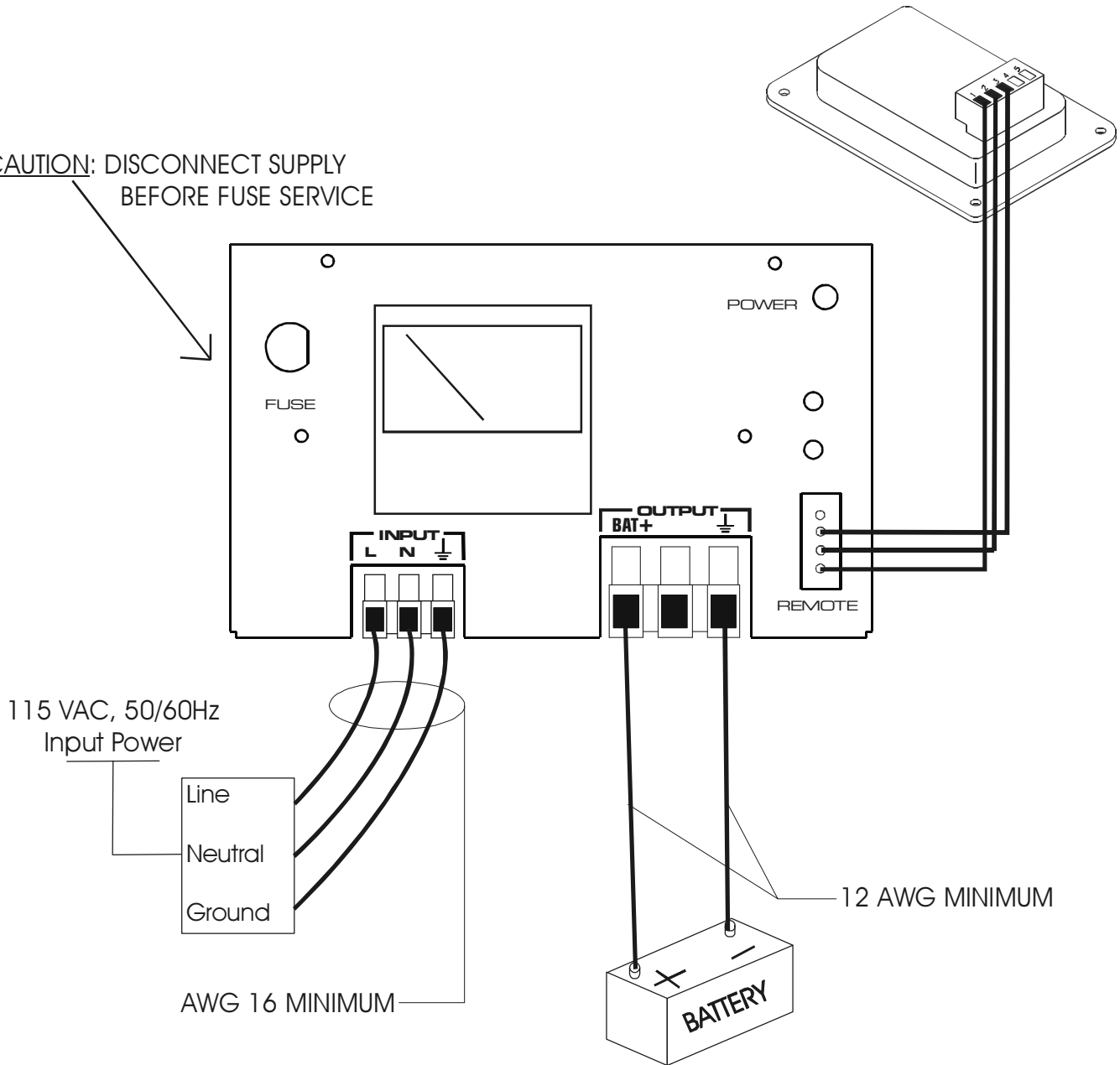

**IMPORTANT:** Wire size is for a maximum length of 20 feet. If wiring is to be longer, larger wiring is required. Additional information is available on request.

# OUTLINE

## SPECIFICATIONS:

Model #	Output Voltage/Current	Input Voltage	Input Current	Current Meter	Weight	Input Fuse
091-170-12	12V/20 Amps	115, 50/60 Hz	2 Amps	25 Amps	16 lb	8 Amp
091-170-24	24V/12 Amps	115, 50/60 Hz	2.5 Amps	15 Amps	15 lb	5 Amp

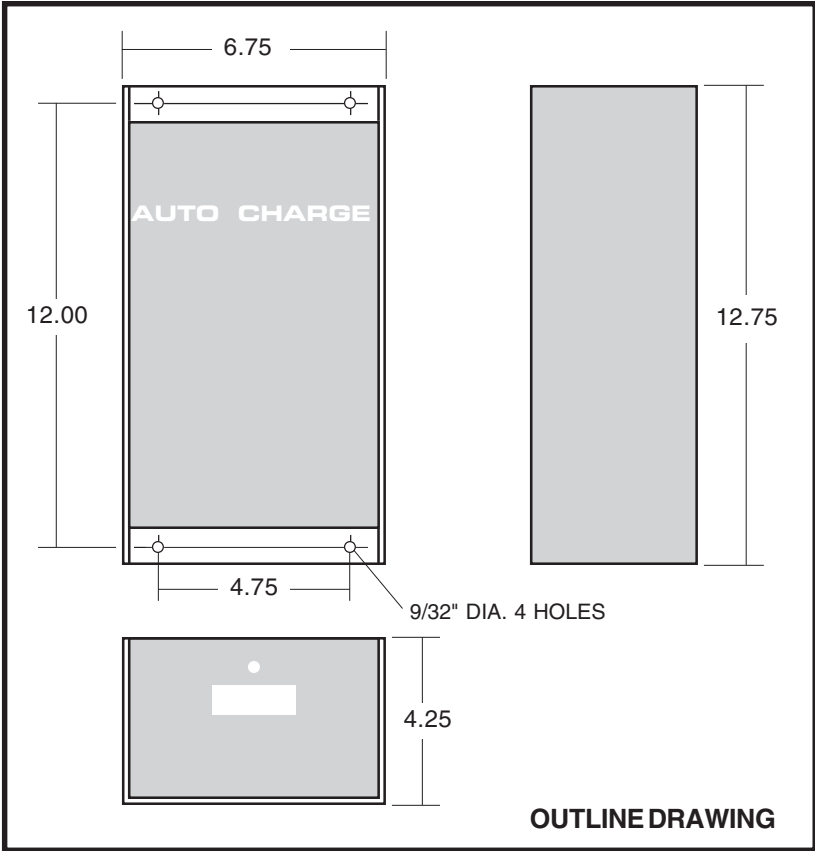

# **INSTALLATION RECORD & WARRANTY**

---

**Date Installed** \_\_\_\_\_

**Installed By** \_\_\_\_\_

**Vehicle Identification** \_\_\_\_\_

**Vehicle Owner** \_\_\_\_\_

## ***WARRANTY***

All product of Kussmaul Electronics Company Inc. are warranted to be free of defects of material or workmanship. Liability is limited to repairing or replacing at our factory, without charge, any material or defects which become apparent in normal use within 3 years from the date the equipment was shipped.

Kussmaul Electronics Company, Inc. shall have no liability for damages of any kind to associated equipment arising from the installation and /or use of the Kussmaul Electronics Company, Inc. products. The purchaser, by the acceptance of the equipment, assumes all liability for any damages which may result from its installation, use or misuse, by the purchaser, his or its employees others.