

## INSTRUCTION MANUAL

---

# AIR EJECT

## AUTOMATIC AIR LINE DISCONNECT

MODEL # 091-28



2 YEAR WARRANTY

---



KUSSMAUL ELECTRONICS CO., INC.

170 CHERRY AVE., WEST SAYVILLE, N.Y. 11796

TEL: 631-567-0314

TOLL FREE: 800-346-0857

FAX: 631-567-5826

WEB: [www.kussmaul.com](http://www.kussmaul.com) E-MAIL: [sales@kussmaul.com](mailto:sales@kussmaul.com)

## INTRODUCTION

---

The Air Eject is a specially designed pneumatic cylinder with an integral solenoid valve which, when the vehicle is started, disconnects the air line connected to it. The Air Eject is supplied with the following components:

1. Cylinder Assy
2. Check Valve
3. Gasket
4. Mounting Screws
5. Mating Female Connector
6. Bezel

## INSTALLATION

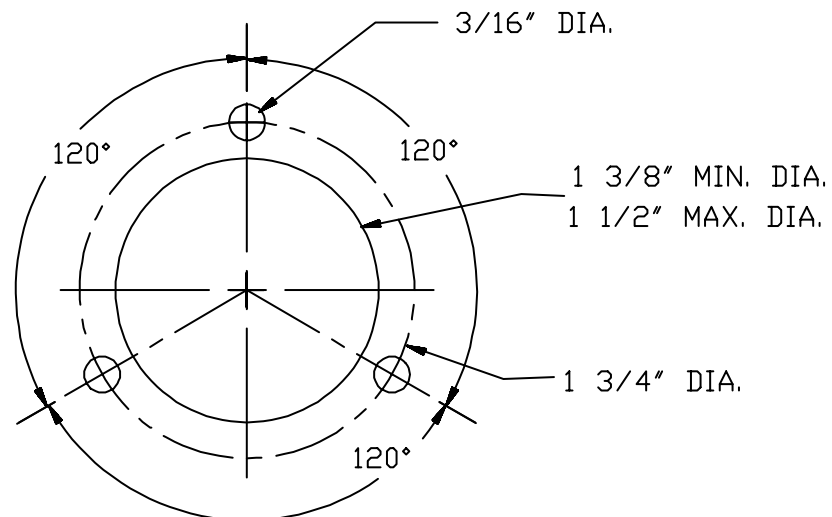

**HOLE TEMPLATE**

**Note:** The 1 3/8" diameter hole is critical. If this hole is too small it will prevent piston from striking Female connector.

# INSTALLATION

1. In order to accurately locate the 3 mounting holes first locate the center of the large hole and mark with a center punch mark. Using a compass scribe 1 3/4" dia. circle. Locate the bezel over this scribed circle, mark the 3 mounting holes & center punch each hole.
2. Drill 3 mounting holes, 3/16" diameter. Drill 1 center hole using hole saw or conduit punch. 1 3/8" diameter.
3. Mount the Cylinder Assembly as illustrated.

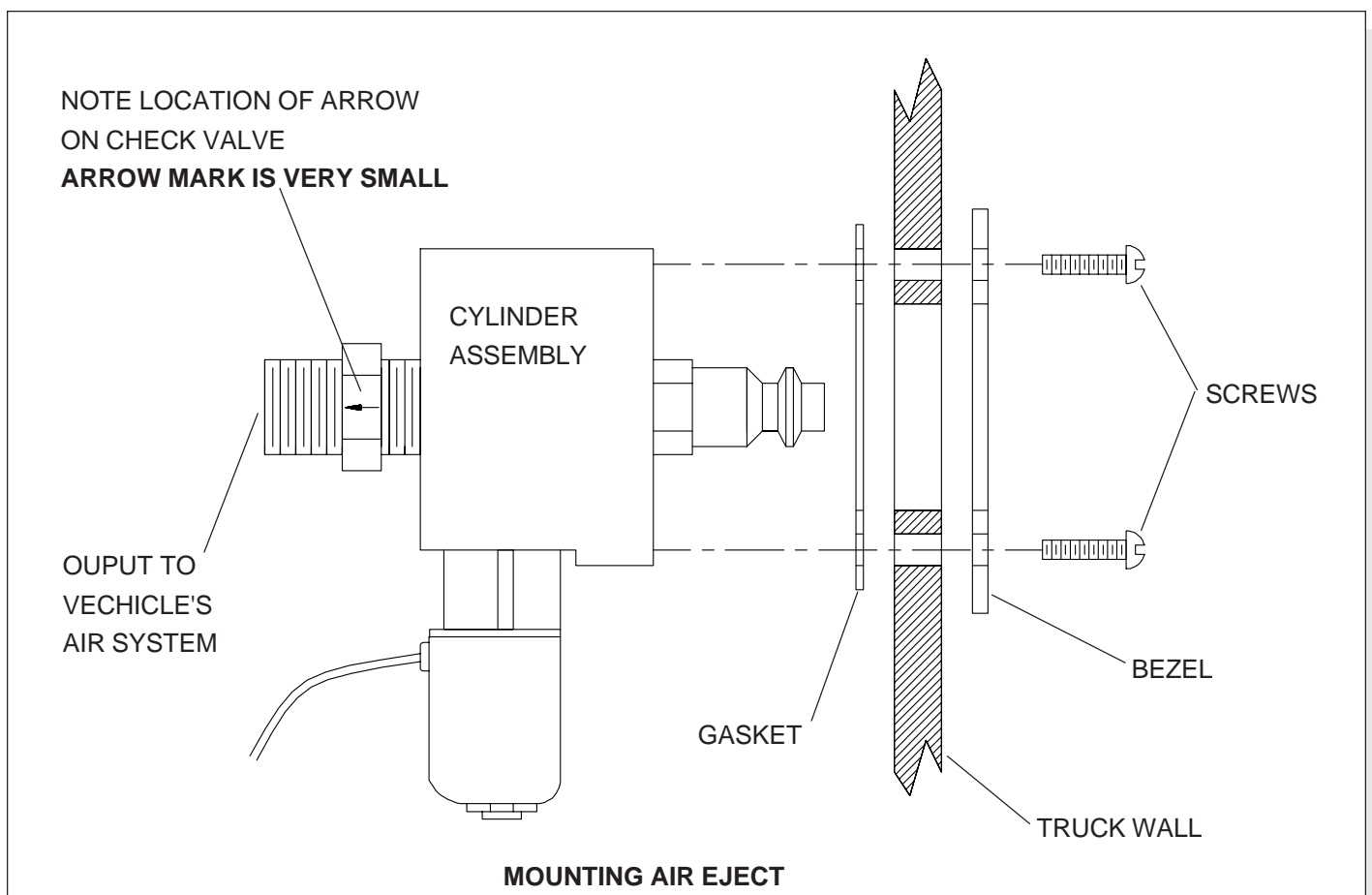

4. Install the check valve being certain that the arrow on the check valve points away from the cylinder assembly.
5. Connect tubing as required to vehicle's air system.

## WIRING

---

1. Wire the solenoid valve to the vehicle's starting circuit. Be certain that the solenoid is energized only while the vehicle is cranking and deenergized at all other times.

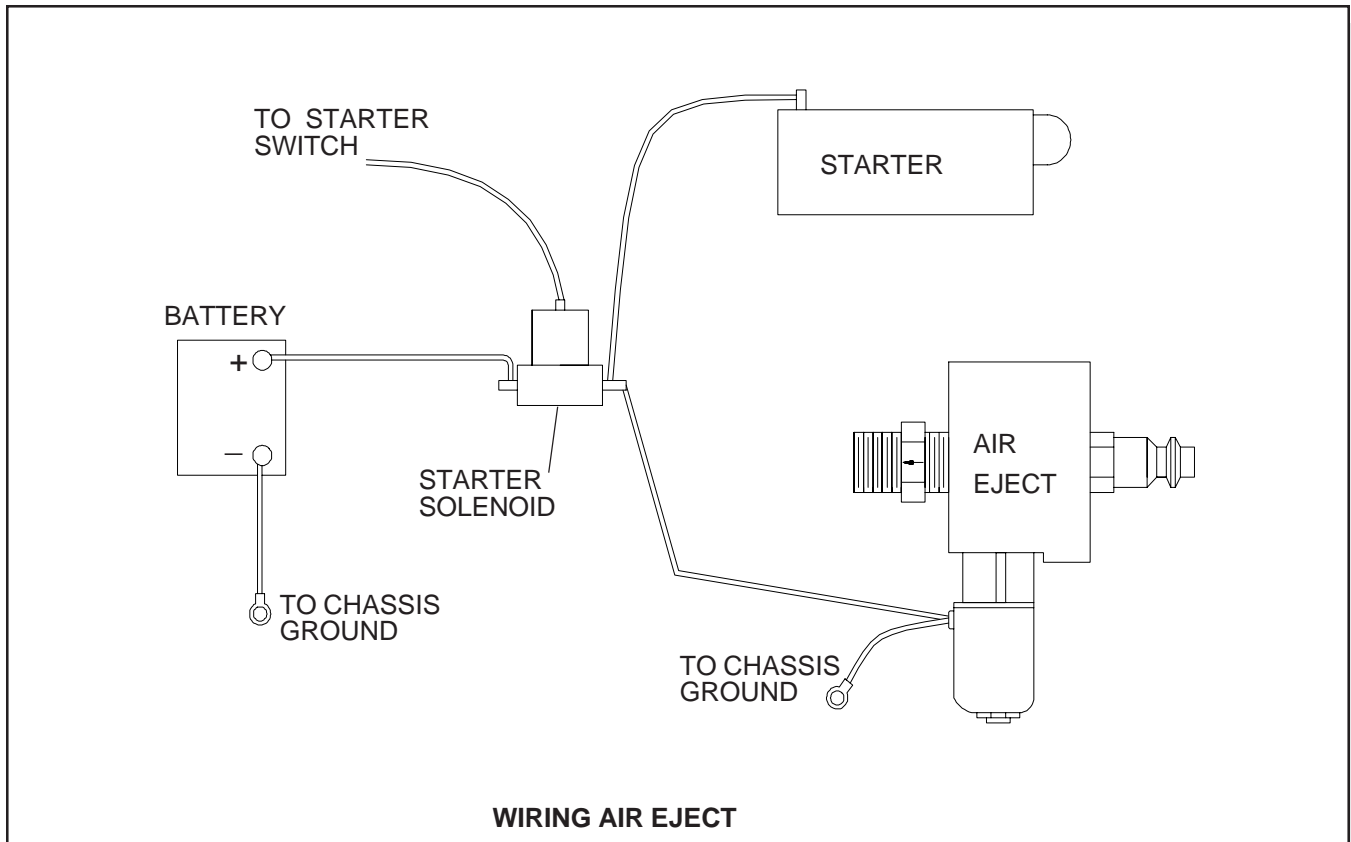

## MAINTENANCE

---

The Air Eject is a precision device designed and manufactured for many years of reliable service. Periodic servicing, cleaning and lubricating are important.

It is suggested that the cylinder assembly be inspected regularly and cleaned and lubricated at a minimum once every six months.

In applications where contamination by water and road dirt are excessive, more frequent servicing may be required.

Lubrication should be only with non-petroleum based lubricants such as Dow Corning DC-4 Silicone grease, Silicone or Teflon spray.

# **INSTALLATION RECORD & WARRANTY**

**Date Installed** \_\_\_\_\_

**Installed By** \_\_\_\_\_

**Vehicle Identification** \_\_\_\_\_

**Vehicle Owner** \_\_\_\_\_

## **WARRANTY**

All products of Kussmaul Electronics Company Inc. are warranted to be free of defects of material or workmanship. Liability is limited to repairing or replacing at our factory, without charge, any material or defects which become apparent in normal use within 2 years from the date the equipment was shipped. Equipment is to be returned, shipping charges prepaid and will be returned, after repair, shipping charges paid.

Kussmaul Electronics Company, Inc. shall have no liability for damages of any kind to associated equipment arising from the installation and /or use of the Kussmaul Electronics Company, Inc. products. The purchaser, by the acceptance of the equipment, assumes all liability for any damages which may result from its installation, use or misuse, by the purchaser, his or its employees or others.

## **ALSO AVAILABLE**



MODEL 091-28AK

### **WEATHERPROOF ADAPTER KIT**

The Weatherproof Adapter Kit provides a recessed mounting for the Air Eject and a gasketed cover which automatically closes when the air line is ejected. A rugged polypropylene sleeve covering the female coupler permits easy manual removal of the air line and protects the coupler from damage during automatic release.



### **NEW COVER**

The weatherproof adapter kit comes with a new cover that has an Air Eject label inserted on the front