

INSTRUCTION MANUAL

AUTO CHARGE 2000

AUTOMATIC BATTERY CHARGER

MODEL # 091-39-12



NOTE :

This charger is designed for vehicles with dual batteries and negative ground.

INPUT : 115 volt, 50/60 Hz, 3.5 amps

OUTPUT: 18 AMPERES

3 YEAR WARRANTY



KUSSMAUL ELECTRONICS CO., INC.

170 CHERRY AVE., WEST SAYVILLE, N.Y. 11796

TEL: in NY 631-567-0314

TOLL FREE: 800-346-0857

FAX: 631-567-5826

INTRODUCTION

The AUTO CHARGE 2000 is a compact, completely automatic, dual channel battery charger designed for vehicles with two batteries. The charger is ruggedized to withstand the shock and vibration encountered by vehicle mounted equipment.

The battery charger features:

- Independent charge controls for each battery
- Electronic remote sensing of true battery voltages, eliminates the need for sensing wires
- Automatic current limiting and apportionment
- Built-in BATTERY SAVER
- Remote dual battery charge/condition indicator
- Power "ON" LED indicator
- BATTERY SAVER overload indicator

DESCRIPTION

Independent Charge Controls & Electronic Remote Sensing

The charger contains two independent charge controls, one for each battery. This allows each battery to be independently charged while maintaining battery isolation. Each battery voltage is remotely sensed, electronically, eliminating the need for four sense wires. Each of the charge controls is completely automatic and stops charging the battery when it is fully charged. There is no trickle charge and therefore no danger of overcharging and water boil-off.

Automatic Current Limiting & Apportionment

The charger contains automatic current limiting at 15 amperes. This is a total current limit for the two batteries combined. The charger automatically apportions the current to each battery. Either battery can draw the total 15 amperes. When charging unequally charged batteries, the lower charged battery receives a higher charge rate. When the batteries are equal, the current is shared equally until they are fully charged at which time the current goes to zero.

Battery Saver & Indicator

A 3 ampere BATTERY SAVER is built into the charger. When connected as shown in the installation wiring diagram, loads on battery #1 such as radios and rechargeable hand lights are automatically switched to the BATTERY SAVER when power is applied to the charger. The BATTERY SAVER allows more efficient charging by removing these loads. A BATTERY SAVER overload indicator alerts the operator that the BATTERY SAVER load has exceeded 3 amperes.

WHEN A BATTERY SAVER OVERLOAD OCCURS:

- a. Remove the loads for approximately two minutes
- b. Reduce the load to 3 amperes or less
- c. Reapply the load to the BATTERY SAVER

No fuses are required or provided as the BATTERY SAVER contains an electronic overload interrupter.

Remote Dual Battery Charge Condition Indicator

This remote indicator shows the charge condition of each battery in 10 levels from "LOW CHARGE" to "FULLY CHARGED". This device indicates a defective battery when a bar graph does not rise to the "FULLY CHARGED" level after an extended period of charging.

NOTE: If a battery is being charged with an external load of 1.5 to 4 amperes across it's terminals, the bar graph may move down 1 or 2 levels. This does not indicate a defective battery.

To avoid this, connect all external loads to the BATTERY SAVER terminals.

Loads connected to the BATTERY SAVER will be powered either from the BATTERY SAVER power supply when the A.C. power is "ON", or they will be connected to battery #1 when the A.C. power is "OFF".

Installation Wiring Diagram

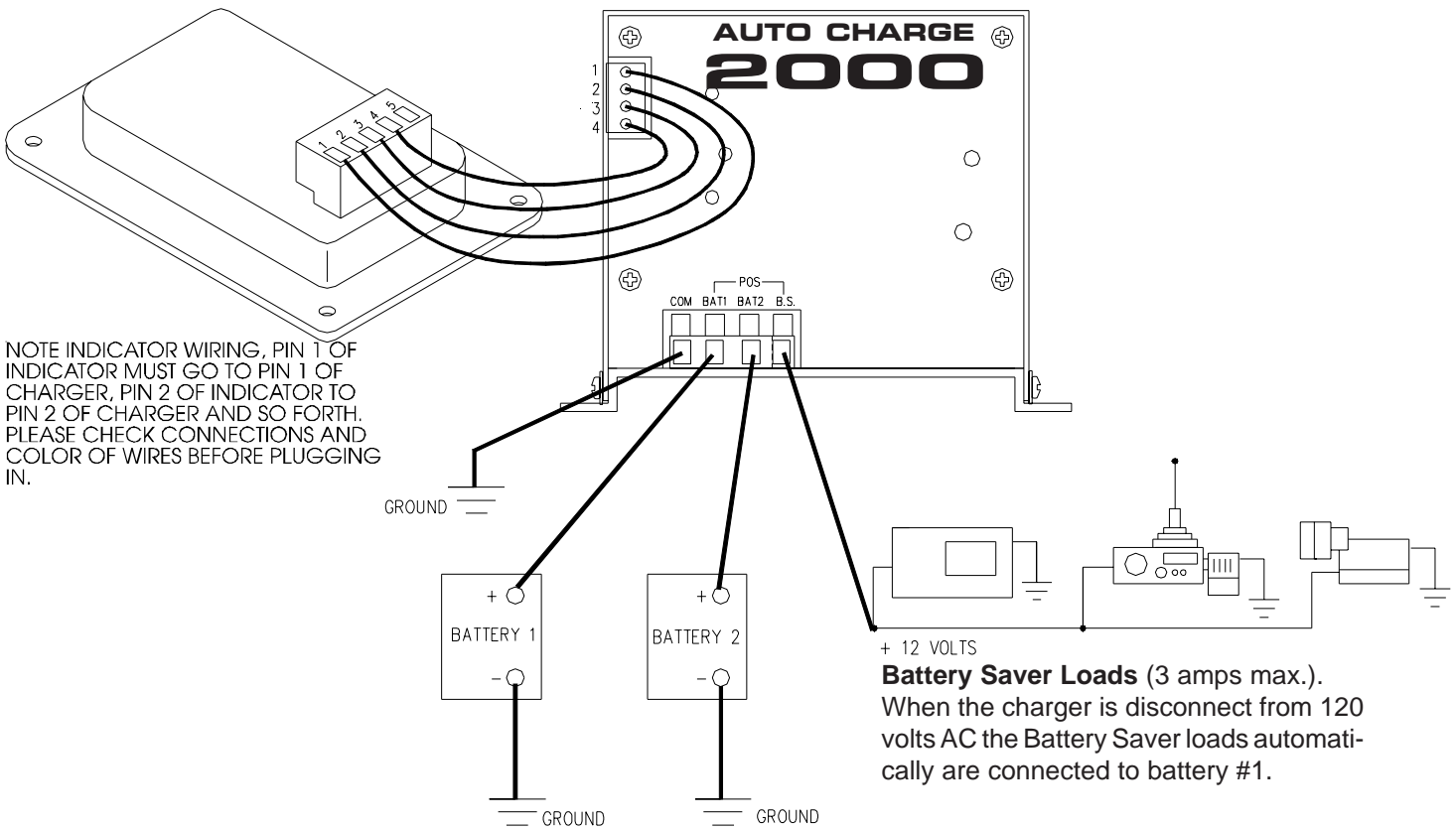

CAUTION BATTERY SAVER

This battery saver output is a full wave rectified sine wave. The 12.5 volts D.C. has a peak value of approximately 17.5 volts.

It is recommended that the loads are not highly capacitive. A large capacitor on the load terminal will "peak detect" the output and create a voltage of approximately 17 volts. This voltage may be too high for the component connected.

It is suggested that the installer check the output of the battery saver (when operating with A.C. Input) and determine as each load is connected that the voltage does not rise. Any load that creates an increase in voltage should not be connected to the battery saver but rather be connected directly to the battery.

WIRE SIZE CHART

CONNECTION	ITEM	DEFINITION	WIRE SIZE
COM	BATTERY COMMON	NEGATIVE CHARGING LEAD FOR CHARGING BATTERIES AND BATTERY SAVER LOAD	14 AWG
BAT 1	BATTERY #1	POSITIVE CHARGING LEAD FOR BATTERY # 1	14 AWG
BAT 2	BATTERY #2	POSITIVE CHARGING LEAD FOR BATTERY # 2	14 AWG
B.S.	BATTERY SAVER	POSITIVE LEAD FOR BATTERY SAVER LOADS.	16 AWG

IMPORTANT : Wire size is for a maximum length of 10 feet. If wiring is to be longer, larger wiring is required. Additional information is available on request.

Specifications:

Input: 120 volt, 50/60 Hz, 3.5 amperes

Input Fuse: 6 ampere, fast acting

Output: 12 volts D.C. 15 amperes Max., total both outputs

Remote Sensing: Electronic, sense wires not required

Number of Charger Outputs: 2

Number of Battery Saver Outputs: 1

Battery Saver Output: 12 volts D.C., 3 amperes Max.

Indicators: **Power:** Red LED, indicates 120 volts power applied

Battery Saver Overload: Yellow LED, indicates Battery Saver load greater than 3 amperes

Dual Bar Graph: indicates charger output to two batteries and state of charge of batteries

Weight: 16 lbs

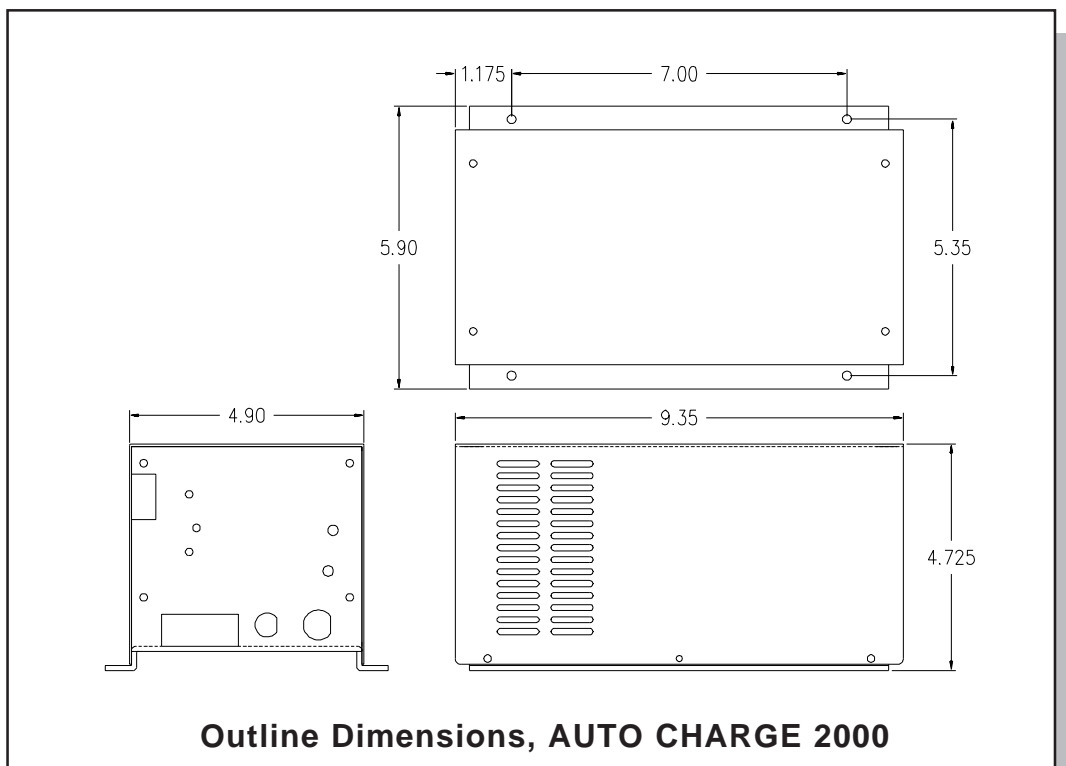

INSTALLATION RECORD & WARRANTY

Date Installed _____

Installed By _____

Vehicle Identification _____

Vehicle Owner _____

WARRANTY

All product of Kussmaul Electronics Company Inc. are warranted to be free of defects of material or workmanship. Liability is limited to repairing or replacing at our factory, without charge, any material or defects which become apparent in normal use within 3 years from the date the equipment was shipped.

Kussmaul Electronics Company, Inc. shall have no liability for damages of any kind to associated equipment arising from the installation and /or use of the Kussmaul Electronics Company, Inc. products. The purchaser, by the acceptance of the equipment, assumes all liability for any damages which may result from its installation, use or misuse, by the purchaser, his or its employees or others.