

PUMP PLUS HO

STANDARD DUAL SYSTEM BATTERY CHARGER



MODEL # 091-9C-HO

The Pump Plus HO battery charger is completely automatic and is for vehicles with dual battery systems. The batteries are automatically charged and maintained fully charged while still being isolated from each other. This new and improved unit contains 2 independent chargers to sense and control the current to the batteries. Thus parasitic loads on one battery have no effect on the other battery. Provision is made also for the connection of remote indicating lights

A Selector Switch is provided on the charger to operate the compressor either in D.C. mode or in A.C. mode. In either switch position the compressor operates from the vehicle's battery. When "D.C." is selected, the compressor operates whenever the pressure switch senses low system pressure. When "A.C." is selected, the compressor operates only when the charger is connected to shoreline power.

SPECIFICATIONS:

Input: 120 Vac, 50/60 Hz, 2.5 Amps Max

Input Fuse: 5 Amps, Fast Acting

Output: 12 Vdc, 11 Amps

Output Fuse (Recommended): 22 Amps

Power Indicator: Indicates Input Power Applied

Weight: 12 lbs

Warranty: 3 Years



ENERGIZED AND READY, WHEN SECONDS COUNT

11 AMPS FOR CHARGING VEHICLE BATTERIES

AUTOMATICALLY CHARGES DUAL BANKS OF BATTERIES

DESIGNED SPECIFICALLY FOR VEHICLES WITH DUAL BATTERY SYSTEMS

EACH BATTERY IS SENSED & CONTROLLED INDIVIDUALLY

AMMETER INDICATES TOTAL OUTPUT

3 YEAR WARRANTY

OPTIONAL INDICATOR



Model IN-4

Remote LED Indicator to show when the charger is Ready or Charging

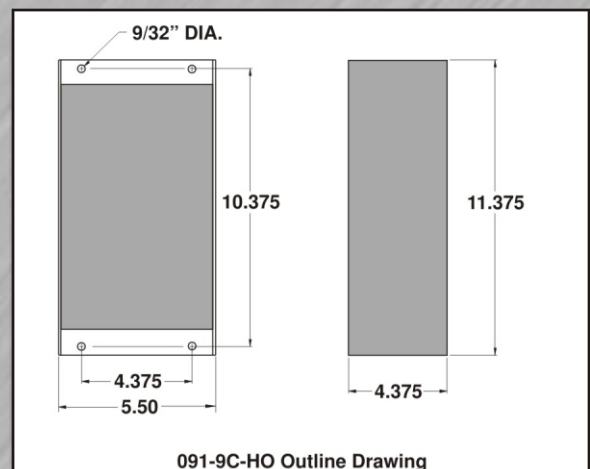

091-9C-HO Outline Drawing

AUTO PUMP® 12 VOLT

AIR BRAKE LEAKAGE COMPENSATOR

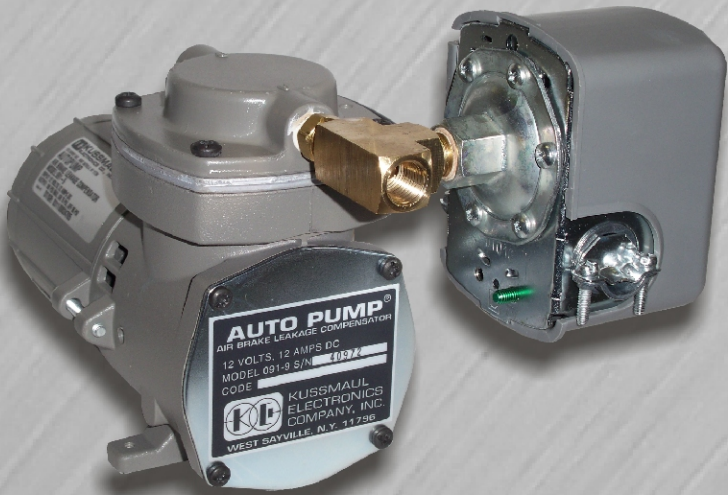

MODEL # 091-9

The 12 Volt Auto Pump is a small air compressor designed to mount on vehicles with air brakes to maintain the air pressure in the air brake system while the vehicle is not in use. A pressure switch senses when the system pressure drops and starts the compressor which then runs until pressure is restored. All ball bearing construction, lubricated for life, assures reliable operation and requires no servicing.

SPECIFICATIONS:

Input: 12 Vdc @ 12 Amps Max

Output: .30 SCFM @ 80 PSI
.35 SCFM @ 60 PSI

Motor Type: Perm. Magnet .10 HP

Pressure Switch: Adjustable Set-Point, Factory set to 75 PSI Cut-In, 95 PSI Cut-Out

Weight: 7 lbs

Warranty: 1 Year



ENERGIZED AND READY, WHEN SECONDS COUNT

100 PSI MAX

MAINTAINS AIR PRESSURE IN THE VEHICLE BRAKE SYSTEM

COMPLETELY AUTOMATIC OPERATION CONTROLLED BY INTEGRAL PRESSURE SWITCH

NO INTERFERENCE WITH OPERATION OF THE ENGINE MOUNTED AIR COMPRESSOR

SMALL SIZE, MOUNTS IN ANY DRY LOCATION

1 YEAR WARRANTY

OPTIONAL ACCESSORY



Model 091-9H

This unit provides a soft mount for the Auto Pump 12 Volt. The mounting plate reduces vibration, and simplifies Auto Pump Installation.

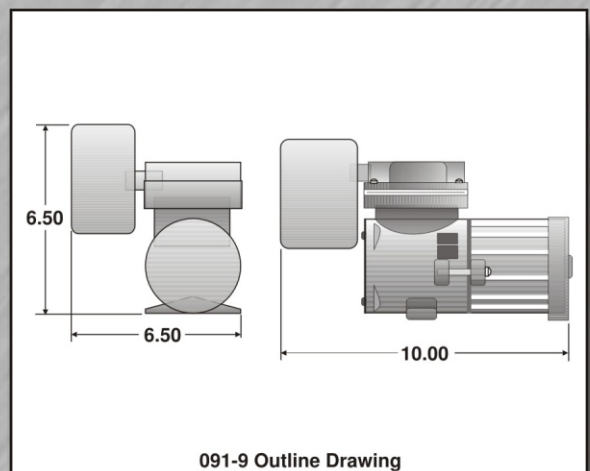

091-9 Outline Drawing