

SAFETY LOCK

AUTOMATIC SAFETY LOCK

**A CONTROLLER WHICH PERMITS
UNATTENDED ENGINE OPERATION
BUT PREVENTS UNAUTHORIZED
USE OF THE VEHICLE**

SIMPLE INSTALLATION

**PERMITS ENGINE
TO RUN WITH THE
IGNITION KEY REMOVED**

**ENGINE STOPS AND CANNOT BE
RESTARTED IF ATTEMPT IS MADE
TO DRIVE AWAY**



MODEL #091-148-24

This simple, low cost controller bypasses the ignition switch when activated by the closure of a momentary switch. The operator may then remove the ignition key without shutting the engine down. Movement of the vehicle is prohibited by interlocking the SAFETY LOCK with a switch operated by the foot brake, a neutral safety switch on the gearshift or a parking brake operated switch. Operating any one of these will cause the relay in the SAFETY LOCK to drop out and interrupt the ignition circuit to stop the engine. The authorized operator need only insert the key and turn on the ignition to operate the vehicle. With the key in the lock and turned on, the ignition circuit is completed as normal and the opening of the SAFETY LOCK relay has no effect on engine operation.

SPECIFICATIONS:

Volts: 24 volts, D.C.

Relay Contacts: Normally Open, 30 Amps.

Weight: 4 ounces

Enclosure: unsealed

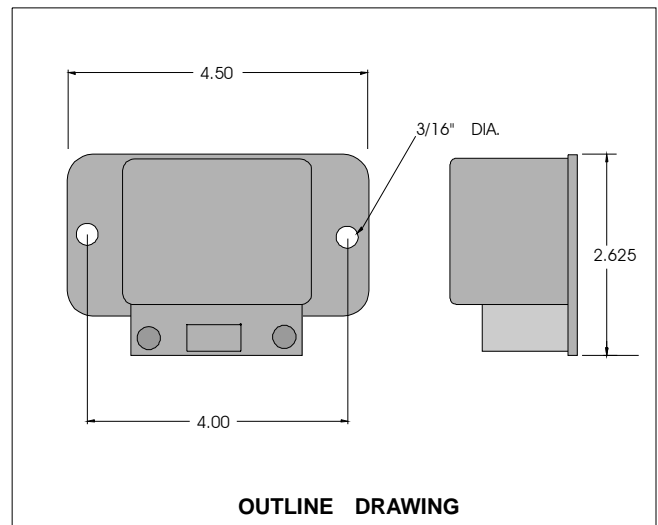

KUSSMAUL ELECTRONICS COMPANY, INC.
170 CHERRY AVE., WEST SAYVILLE, NY 11796

TELEPHONE in NY: 631-567-0314 TOLL FREE: 800-346-0857 FAX: 631-567-5826 e-mail: sales@kussmaul.com

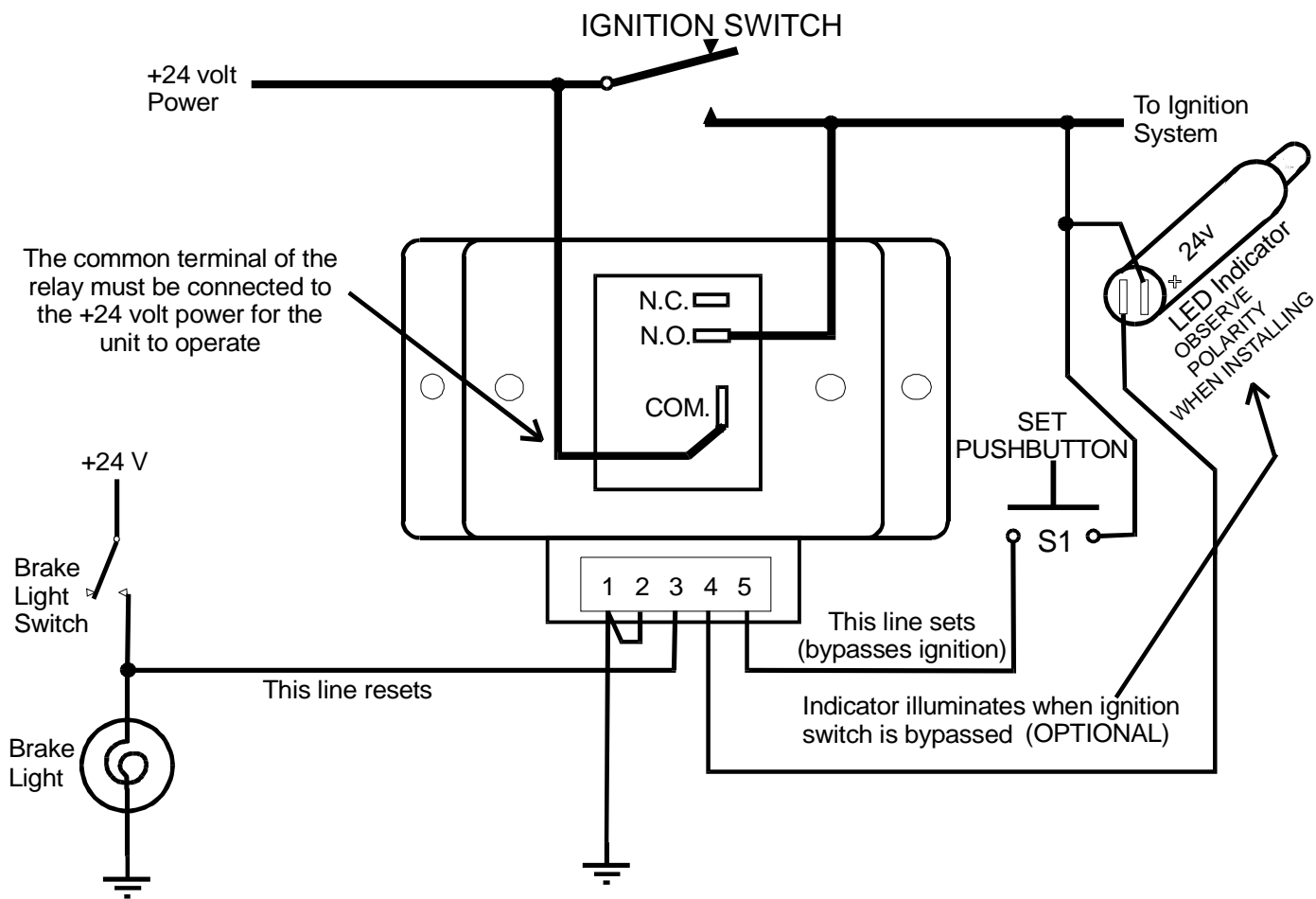

INSTALLATION:

1. Mount unit in a suitable location protected from moisture and excessive heat.
2. Wire in accordance with the wiring diagram above

OPERATION:

1. With the engine running depress the momentary SET switch S1. The relay will close, the LED will be illuminated and the engine will continue to run when the key is removed.
2. Remove the key from the ignition. The LED will continue to be illuminated and the engine will continue to run.
3. Step on the foot brake. The LED will go out and the engine will stop.
4. Start the engine and repeat step 1.
5. Insert the key, turn ignition switch to ON and verify that the engine continues to run when the brake pedal is depressed.

MODEL 091-148-24

SAFETY LOCK

A Controller To Permit Engine Operation With The Ignition Switch Removed

INSTALLATION AND WIRING INSTRUCTIONS



SINCE 1967, DESIGNERS OF INNOVATIVE PRODUCTS

KUSSMAUL ELECTRONICS COMPANY, INC.

170 CHERRY AVENUE, WEST SAYVILLE, NEW YORK, 11796-1221 USA TEL: 631-567-0314, FAX: 631-567-5826,