

INSTRUCTION MANUAL

AUTO CHARGE 12 DV AUTOMATIC BATTERY CHARGER



MODEL # 091-165-24-DV
INPUT: 115 or 230VAC, 50/60Hz
OUTPUT: 24VDC, 6 Amperes

NOTE :
This charger is designed for
vehicles with a single
battery system

3 YEAR WARRANTY



KUSSMAUL ELECTRONICS CO., INC.
170 CHERRY AVE., WEST SAYVILLE, N.Y. 11796-1221

Phone: 631-567-0314

Toll Free: 800-346-0857

Fax: 631-567-5826

Web: www.kussmaul.com

E-Mail: sales@kussmaul.com

INTRODUCTION

This manual describes the installation and wiring for the Auto-Charge 12DV Automatic Battery Charger. It is suggested that the installer read the entire instruction manual to become familiar with the tasks involved before operating the charger.

INSTALLATION

The installation of the vehicle wiring must provide a direct connection between the battery [+,-] terminals and the Auto-Charge 12DV, Model: 091-165-24-DV, Automatic Battery Charger. The battery is automatically charged at constant voltage. For deeply discharged batteries or if the charger is operated while the vehicle is started, a current limiter automatically limits the output to 6 amperes. Input power may be either 115 VAC or 230 VAC, 50 or 60 Hz. A recessed input voltage selector switch is provided on the charger front panel near the input terminal strip.

The Auto-Charge 12DV uses remote sensing via the charging wires to the battery under charge and therefore only the battery charging wires are necessary to connect to the battery to the charger. These connections are made on the "OUTPUT" terminal strip. Refer to FIGURE 1, Installation Wiring Diagram.

The Auto-Charge 12DV Automatic Battery Charger should be installed in an area with adequate ventilation. A switch on the front panel of the charger selects either "115V" or "230V" VAC. Set this switch to the proper position to correspond to the input voltage before applying power to the charger.

1. Mount the charger using the four holes provided. Refer to "OUTLINE DRAWING, FIGURE 2.
2. Connect the wiring from the batteries to the Output Terminal Strip. Spade lugs that have been securely crimped or soldered should be used.
3. Connect the wiring to the batteries. Ring lugs that have been securely crimped or soldered should be used.
4. Double check all wiring before proceeding.
5. Wire the VAC input power line to the power source and check the position of the Voltage Selector Switch.
6. The pilot light will light to show that the charger has power.
7. The ammeter will indicate how much current is flowing to the battery. A charging current limit of 12 amperes is factory set.

*******IMPORTANT SAFETY INSTRUCTIONS*******

**DO NOT APPLY 230 VOLTS TO THE CHARGER WITH
115/230VAC SELECTOR SWITCH IN THE 115 VOLT POSITION
SERIOUS DAMAGE WILL RESULT**

INSTALLATION WIRING DIAGRAM

FIGURE 1

Optional Bar-graph
Indicator
091-165-031

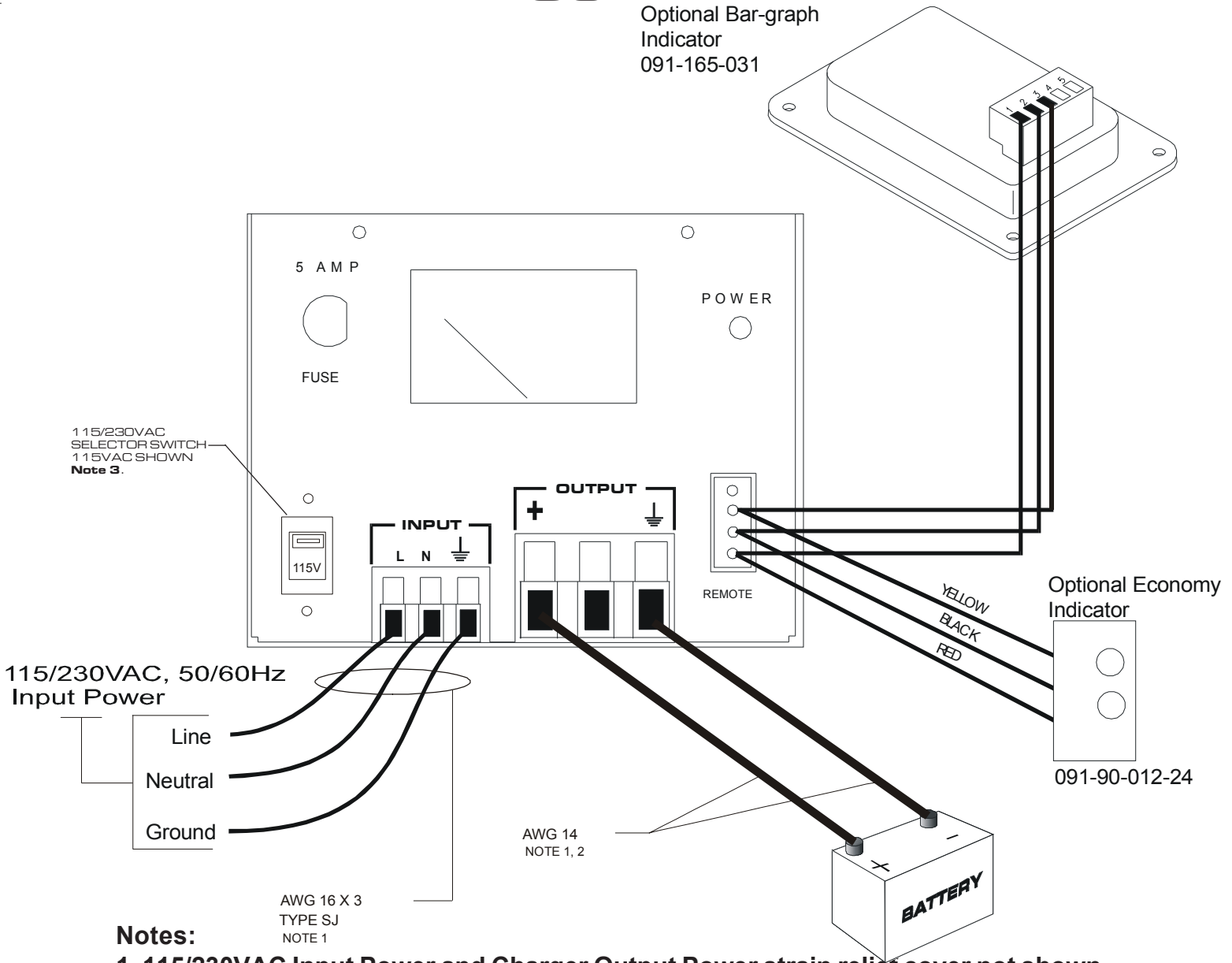

Notes:

1. 115/230VAC Input Power and Charger Output Power strain relief cover not shown for clarity. Refer to INSTALLATION "Important Safety Instructions" section of this manual.
2. Charger output power connections, AWG 14, for 20 feet Maximum. Consult factory if longer length is required.
3. 115VAC operation shown. For 230VAC toggle voltage select switch down so that "230V" is clearly shown in window of selector switch.

SPECIFICATION & OUTLINE

SPECIFICATIONS:

Input: 115/230VAC, 50/60 Hz, 3/1.5 Amps

Input Fuse: 3 Amps, **CAUTION: DISCONNECT SUPPLY BEFORE CHANGING FUSE**

Output: 24VDC

Output Fuse (Optional): 12 Amps

Output Current: 6 Amps

Charge Indicator: 0-15 amps +/-5%

Weight: 10 lbs

FIGURE 2

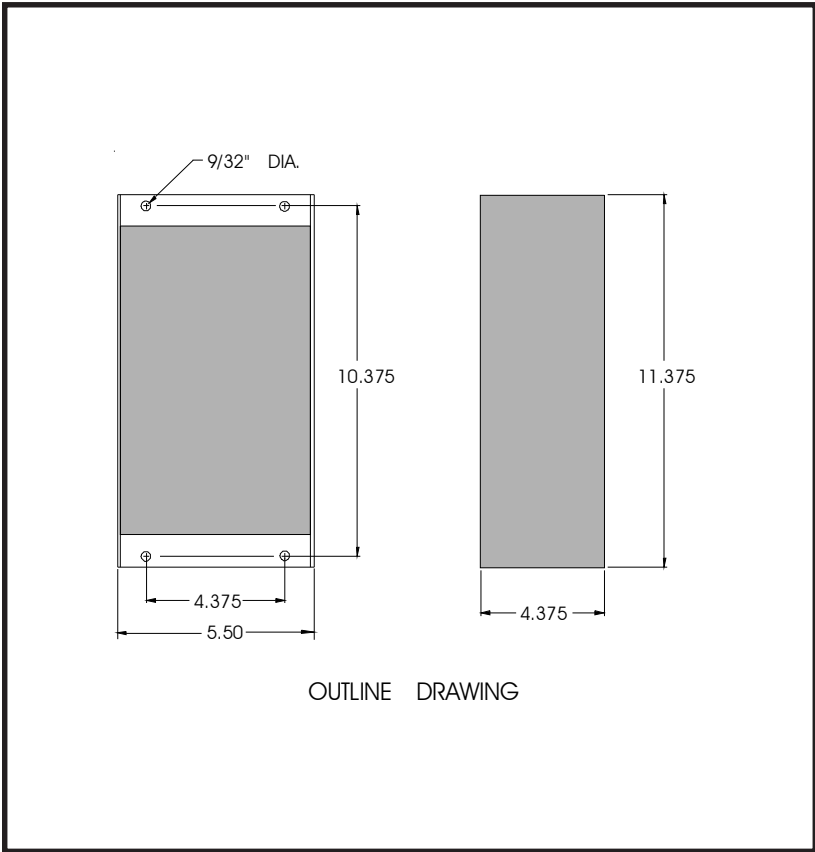

INDICATOR INSTALLATION

1. Locate Indicator in a convenient place on the vehicle.
2. Place the template in position and center punch in 4 places.
3. Drill holes as shown.
4. Cut out square hole.
5. Connect wiring to charger in accordance with the instructions in the charger installation instructions.
6. Install as shown.
7. Insert (4) #8-32 screws supplied and tighten. (**CAUTION: Do not over tighten because you will bend the plastic bezel and break the watertight seal).**

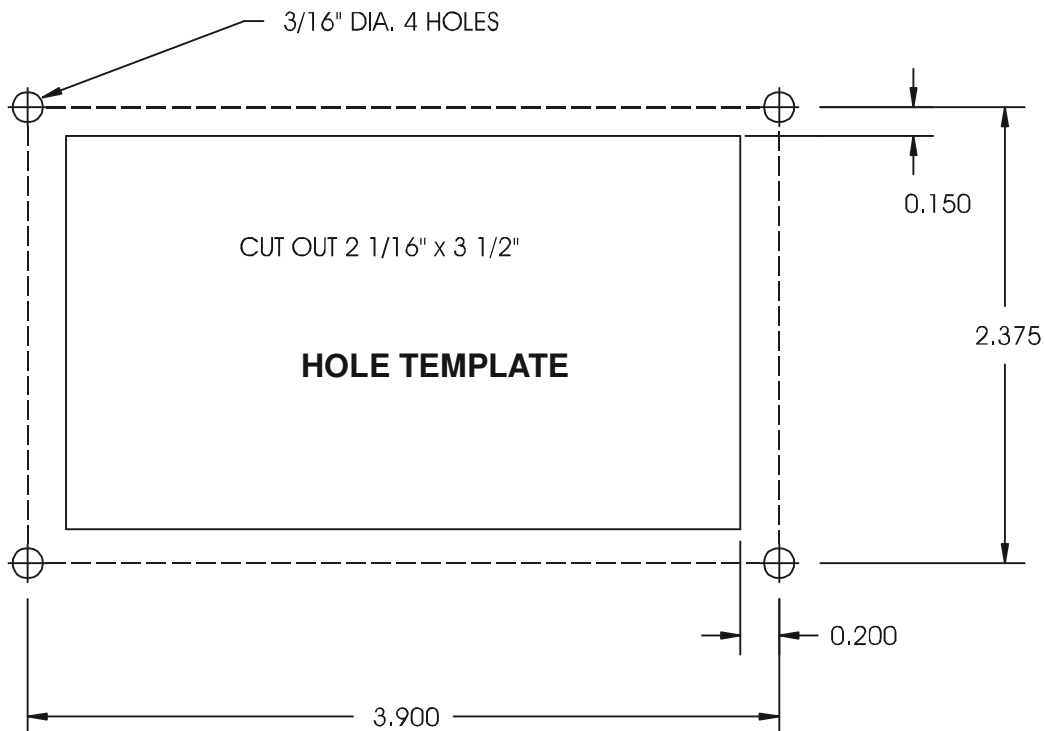
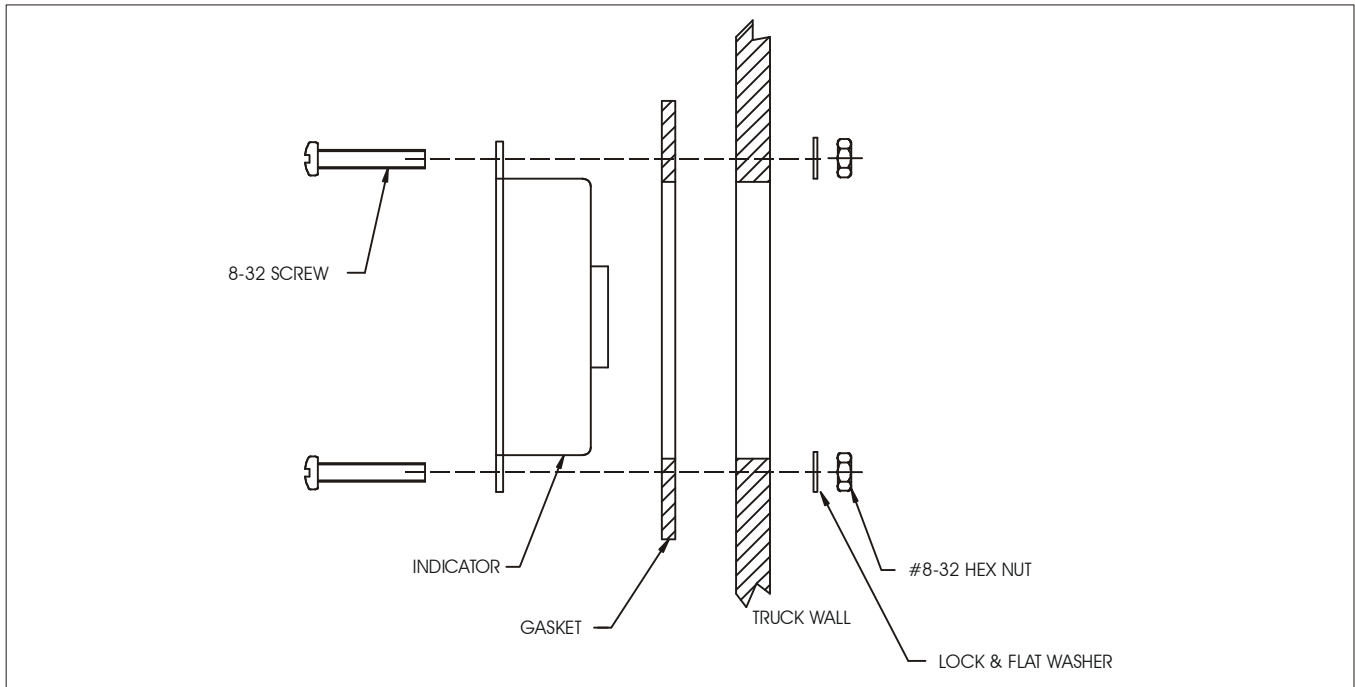

Hole Template may not be to Scale, please check dimensions before using.

INSTALLATION RECORD & WARRANTY

Date Installed _____

Installed By _____

Vehicle Identification _____

Vehicle Owner _____

WARRANTY

All product of Kussmaul Electronics Company Inc. are warranted to be free of defects of material or workmanship. Liability is limited to repairing or replacing at our factory, without charge, any material or defects which become apparent in normal use within 3 years from the date the equipment was shipped.

Kussmaul Electronics Company, Inc. shall have no liability for damages of any kind to associated equipment arising from the installation and /or use of the Kussmaul Electronics Company, Inc. products. The purchaser, by the acceptance of the equipment, assumes all liability for any damages which may result from its installation, use or misuse, by the purchaser, his or its employees or others.