

INSTRUCTION MANUAL

SUPER AUTO EJECT

AUTOMATIC SHORE LINE DISCONNECT

MODEL 091-182-230-XX



2 YEAR WARRANTY



KUSSMAUL ELECTRONICS CO., INC.

170 CHERRY AVE., WEST SAYVILLE, N.Y. 11796

Phone: 631-567-0314

Toll Free: 800-346-0857

Fax: 631-567-5826

Web: www.kussmaul.com

E-Mail: sales@kussmaul.com

CAUTION

The AUTO EJECT must be connected to the starter circuit so that the solenoid is energized only while the engine is cranking. If the solenoid is energized continuously it will OVERHEAT and BURN OUT.

**FAILURE TO FOLLOW
THIS CAUTION NOTE
WILL VOID THE
WARRANTY**

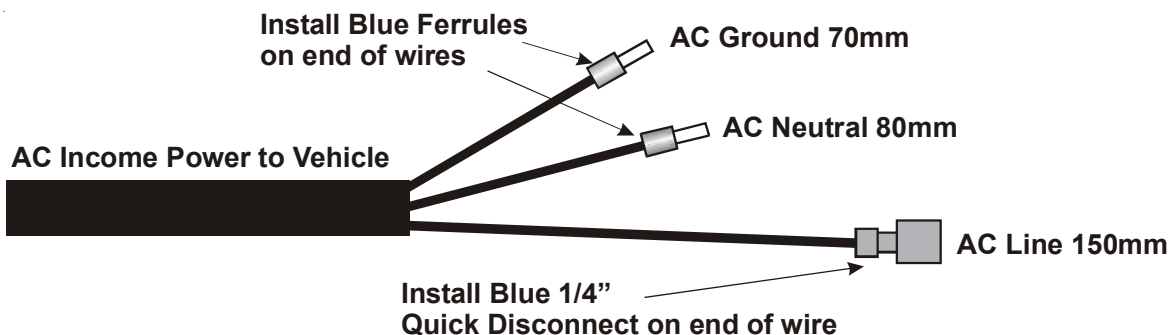
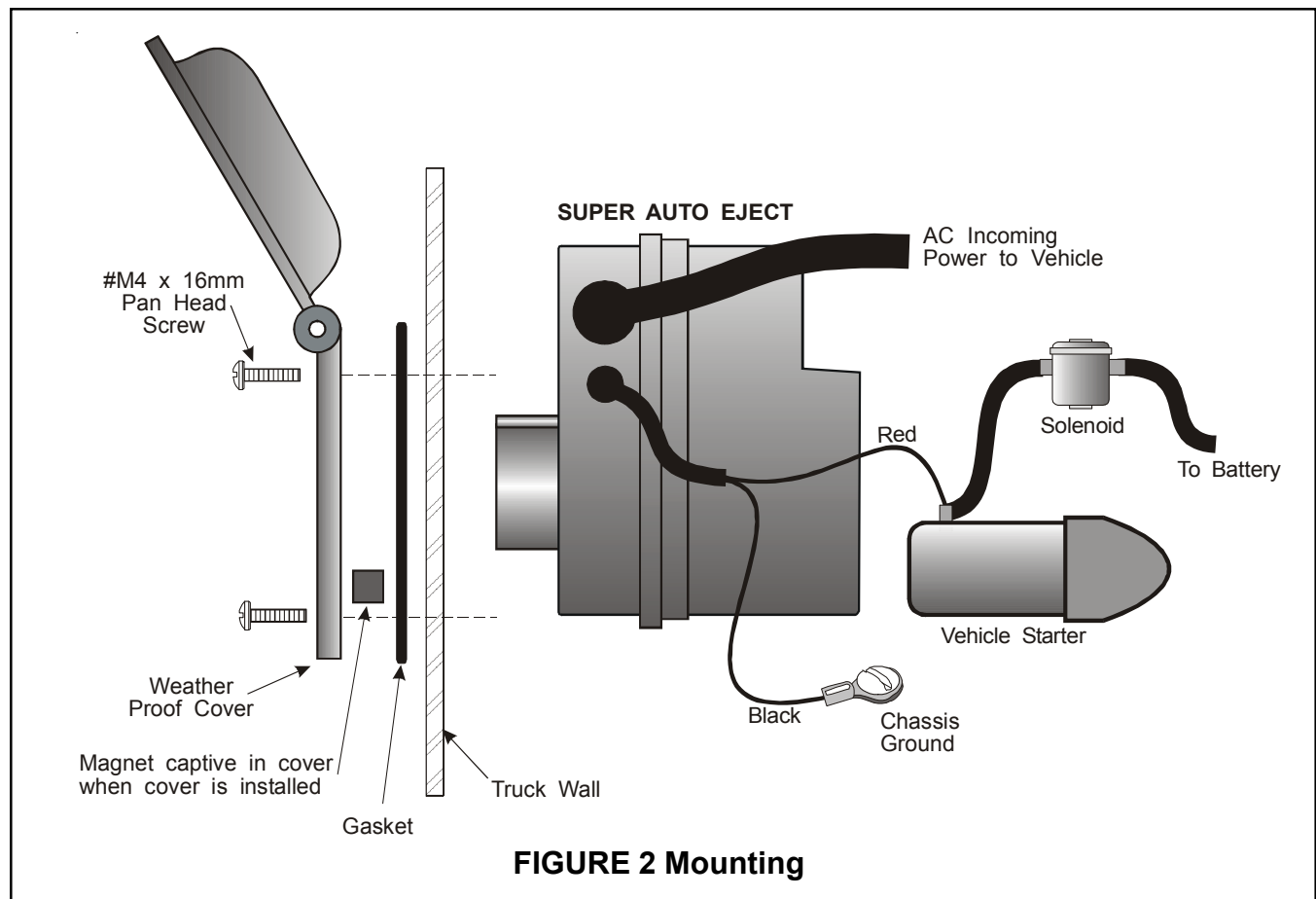

FIGURE 1 AC Wire Preparation

INSTALLATION INSTRUCTIONS

1. Locate a convenient place on the vehicle to mount the AUTO EJECT. A minimum clearance of 4 5/8"(115mm) behind the mounting panel is required.
2. Place the Hole Template in position and center punch and drill in 6 places.
3. Mount the Auto Eject as shown in Figure 2.
4. Connect the DC wiring. Install the DC cable, use the 2 white connectors as shown in Figure 3. USE #16 GAUGE WIRE OR HEAVIER.
5. Connect the AC wiring. Prepare the AC cable as shown in Figure 1. Then install the AC cable as shown in Figure 3. USE #14 GAUGE WIRE OR HEAVIER.
6. Test installation by installing mating connector into the AUTO EJECT. Energizing the starter should energize the solenoid and eject the connector.
7. Keep connector and contacts of the AUTO EJECT clean. Lubricate contacts bi-annually with graphite petrolatum to insure free operation.

Note: USE ONLY CORD CONNECTOR (PLUG) SUPPLIED WITH THE AUTO EJECT
All connectors are not identical, using a substitute may result in unreliable operations or failure of the AUTO EJECT to operate.



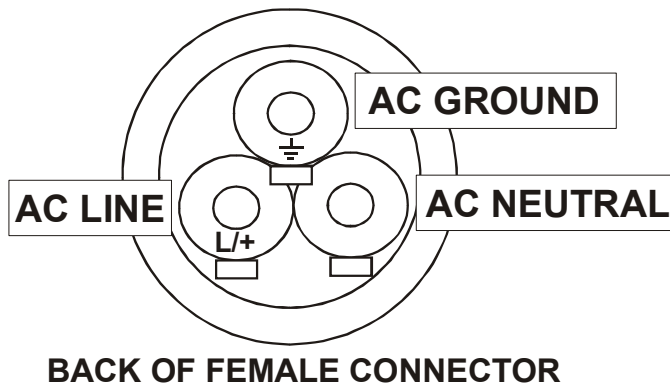
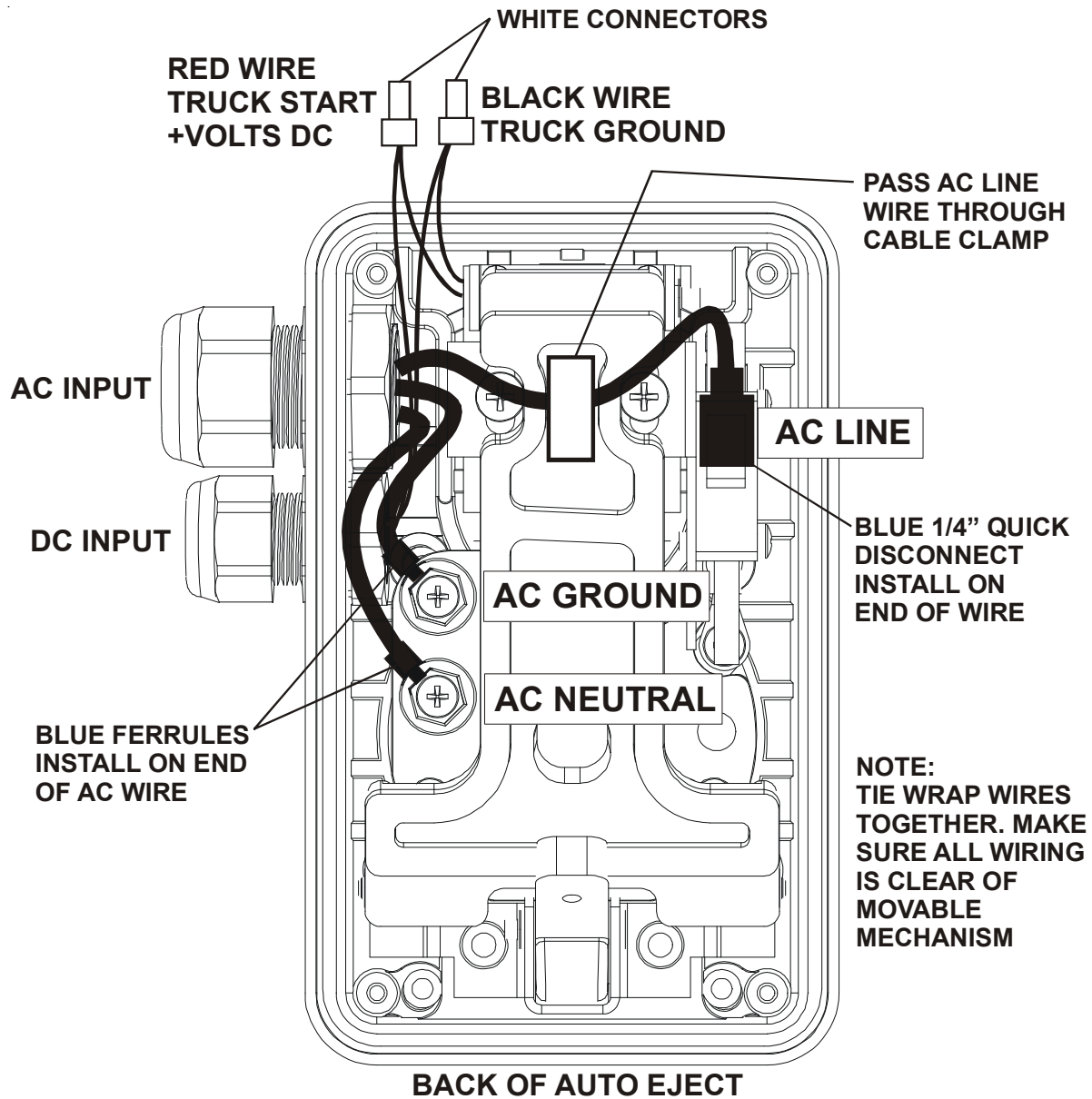
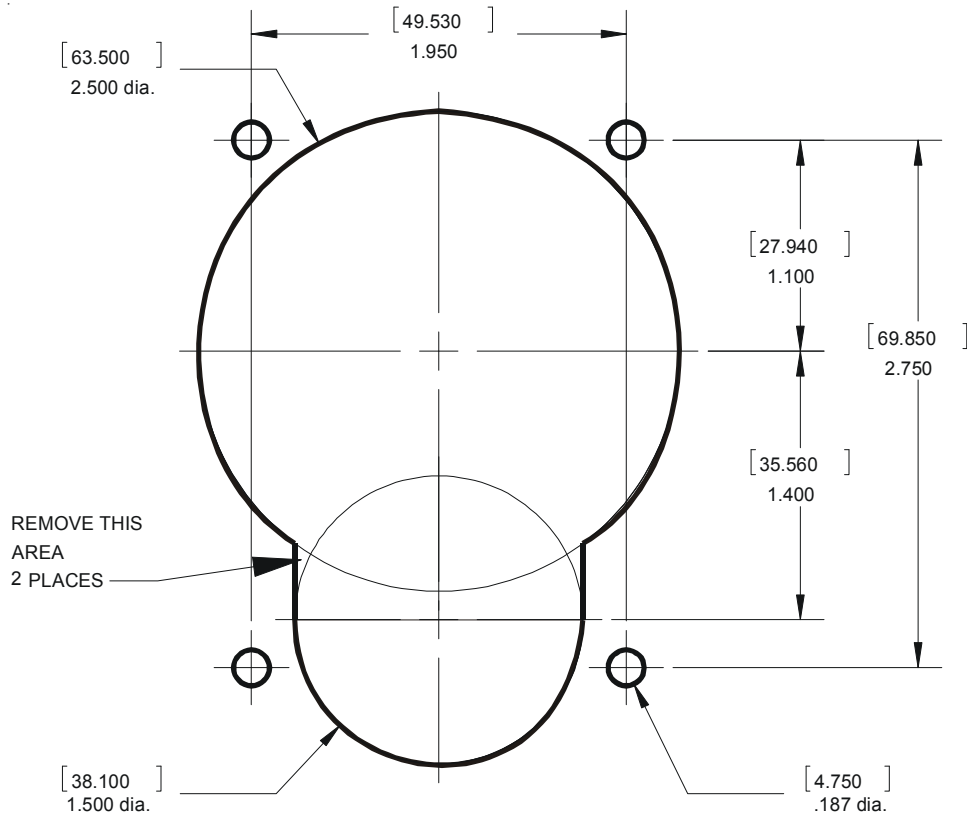

FIGURE 3 Wiring



HOLE TEMPLATE

2 YEAR WARRANTY

All Auto Ejects manufactured by Kussmaul Electronics Company Inc. are warranted to be free of defects of material or workmanship. Liability is limited to repairing or replacing at our factory, without charge, any material or defects which become apparent in normal use within 2 years from the date the equipment was shipped. Equipment is to be returned, shipping charges prepaid and will be returned, after repair, shipping charges paid.

This warranty does not include normal wear and tear, pitting of the electrical contacts, malfunction due to contamination of the mechanism, or solenoid overheating due to improper installation.

Kussmaul Electronics Company, Inc. shall have no liability for damages of any kind to associated equipment arising from the installation and /or use of the Kussmaul Electronics Company, Inc. products. The purchaser, by the acceptance of the equipment, assumes all liability for any damages which may result from its installation, use or misuse, by the purchaser, his or its employees or others.