

INSTRUCTION MANUAL

AUTO CHARGE 2 AUTOMATIC BATTERY CHARGER



MODEL #091-29-XX

3 YEAR WARRANTY



KUSSMAUL ELECTRONICS CO., INC.
170 CHERRY AVE., WEST SAYVILLE, N.Y. 11796

SPECIFICATION & OUTLINE

SPECIFICATIONS:

Input: see chart

Output: see chart

Output Current: see chart

Charge Indicator: LED

Weight: 3.5 lbs

Model #	Output Current	Output Voltage	Output Ripple	Input Voltage	Input Current
091-29-6	3.0 Amps	6	60 MV	120, 50/60 Hz	1 Amps
091-29-12	3.0 Amps	12	60 MV	120, 50/60 Hz	1 Amps
091-29-24	2.0 Amps	24	100 MV	120, 50/60 Hz	1 Amps
091-29-36	1.5 Amps	36	150 MV	120, 50/60 Hz	1 Amps
091-29-48	1.0 Amps	48	200 MV	120, 50/60 Hz	1 Amps
091-29-72	0.75 Amps	72	300 MV	120, 50/60 Hz	1 Amps
091-29-96	0.50 Amps	96	400 MV	120, 50/60 Hz	1 Amps
091-29-120	0.40 Amps	120	500 MV	120, 50/60 Hz	1 Amps
091-29-6-230	3.0 Amps	6	60 MV	230, 50/60 Hz	0.6 Amps
091-29-12-230	3.0 Amps	12	60 MV	230, 50/60 Hz	0.6 Amps
091-29-24-230	2.0 Amps	24	100 MV	230, 50/60 Hz	0.6 Amps
091-29-36-230	1.5 Amps	36	150 MV	230, 50/60 Hz	0.6 Amps
091-29-48-230	1.0 Amps	48	200 MV	230, 50/60 Hz	0.6 Amps
091-29-72-230	0.75 Amps	72	300 MV	230, 50/60 Hz	0.6 Amps
091-29-96-230	0.50 Amps	96	400 MV	230, 50/60 Hz	0.6 Amps
091-29-120-230	0.40 Amps	120	500 MV	230, 50/60 Hz	0.6 Amps

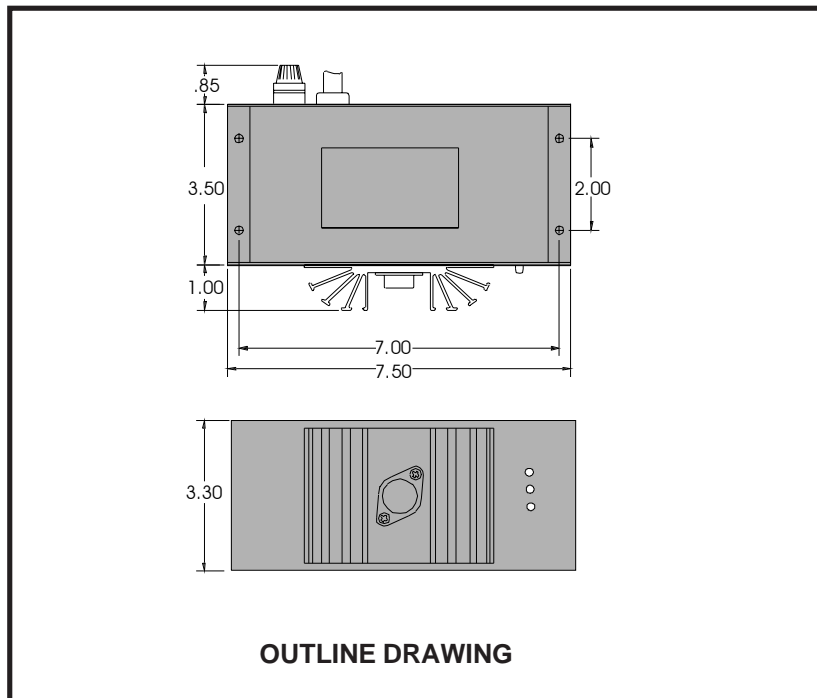

INSTALLATION RECORD & WARRANTY

Date Installed _____

Installed By _____

Vehicle Identification _____

Vehicle Owner _____

WARRANTY

All product of Kussmal Electronics Company Inc. are warranted to be free of defects of material or workmanship. Liability is limited to repairing or replacing at our factory, without charge, any material or defects which become apparent in normal use within 3 years from the date the equipment was shipped.

Kussmal Electronics Company, Inc. shall have no liability for damages of any kind to associated equipment arising from the installation and /or use of the Kussmal Electronics Company, Inc. products. The purchaser, by the acceptance of the equipment, assumes all liability for any damages which may result from its installation, use or misuse, by the purchaser, his or its