

INSTRUCTION MANUAL

AUTO CHARGE 4000 AUTOMATIC BATTERY CHARGER



MODEL # 091-89-12

**INPUT : 120 volt, 50/60 Hz, 8 amps
OUTPUT: 40 AMPERES**

3 YEAR WARRANTY

170 Cherry Avenue
West Sayville, NY 11796
www.kussmaul.com

**KE KUSSMAUL™
ELECTRONICS**
ENERGIZED AND READY, WHEN SECONDS COUNT

Ph: 800-346-0857
Fax: 631-567-5826
sales@kussmaul.com

CAUTION

This battery saver output is a full wave rectified sine wave. The 12.5 volts D.C. has a peak value of approximately 17.5 volts.

It is recommended that the loads are not highly capacitive. A large capacitor on the load terminal will "peak detect" the output and create a voltage of approximately 17 volts. This voltage may be too high for the component connected.

It is suggested that the installed check the output of the battery saver (when operating with A.C. input) and determine as each load is connected that the voltage does not rise. Any load that creates an increase in voltage should not be connected to the battery saver but rather be connected directly to the battery.



SINCE 1967, DESIGNERS OF INNOVATIVE PRODUCTS

KUSSMAUL ELECTRONICS COMPANY, INC.

170 CHERRY AVENUE, WEST SAYVILLE, NEW YORK, 11796-1221 USA

TEL. In NY: 631 567-0314

TOLL FREE: 800 346-0857

FAX: 631 567-5826

INTRODUCTION

The Auto Charge 4000 is a compact, completely automatic, dual channel battery charger designed for vehicles with a dual battery system. The charger is ruggedized to withstand the shock and vibration encountered by vehicle mounted equipment.

Charger features:

- Independent charge controls for each battery
- Electronic remote sensing of true battery voltages, eliminates the need for sensing wires
- Automatic current limiting
- Built-in BATTERY SAVER
- Remote dual battery charge/condition indicator
- Power "ON" LED indicator
- BATTERY SAVER overload indicator

CHARGE CONTROLS & ELECTRONIC REMOTE SENSING

The Auto Charge 4000 contains two independent charge controls, one for each battery. Automatic electronic remote sensing measures the true voltage of each battery, eliminating the need for the additional sense wires. The output current of any charger is inherently a series of pulses whose frequency is determined by the power line frequency. Therefore there are brief intervals during which no charging current flows. During this brief interval the Auto Charge 4000 measures and stores the battery voltage. This voltage is compared to a standard and any error is detected and used to control the charger output to the desired level. There is no "trickle charge" and therefore no danger of overcharging and water boil-off.

AUTOMATIC CURRENT LIMITING

When batteries are severely discharged, some battery chargers can be overloaded due to the high charging current required. The Auto Charge 4000 contains an automatic current limit. This current limits the output current to the rated 40 amperes when charging a deeply discharged battery or if the starter cranks the engine while charging. The current limiter thus eliminates the need for an ignition interlock circuit.

BATTERY SAVER & INDICATOR

A 5 ampere BATTERY SAVER is built into the charger. When connected as shown in the installation wiring diagram, loads on the battery such as radios and rechargeable hand lights are automatically switched to the BATTERY SAVER when power is applied to the charger. The BATTERY SAVER allows more efficient charging by removing these loads. A BATTERY SAVER overload indicator alerts the operator that the BATTERY SAVER load has exceeded 5 amperes.

WHEN A BATTERY SAVER OVERLOAD OCCURS:

- a. Remove the loads for approximately two minutes
- b. Reduce the load to 5 amperes or less
- c. Reapply the load to the BATTERY SAVER

No fuses are required or provided as the BATTERY SAVER contains an automatic circuit breaker.

REMOTE BATTERY CHARGE CONDITION INDICATOR

This remote indicator shows the charge condition of each battery in 10 levels from “LOW CHARGE” to “FULLY CHARGED”. This device indicates a defective battery when a bar graph does not rise to the “FULLY CHARGED” level after an extended period of charging.

NOTE: If a battery is being discharged with an external load of 1.5 to 6 amperes across it's terminals, the bar graph may move down 1 or 2 levels. This does not indicate a defective battery.

To avoid this, connect all external loads to the BATTERY SAVER terminals.

Loads connected to the BATTERY SAVER will be powered either from the BATTERY SAVER power supply when the A.C. power is “ON”, or they will be connected to battery #1 when the A.C. power is “OFF”.

Installation Wiring Diagram

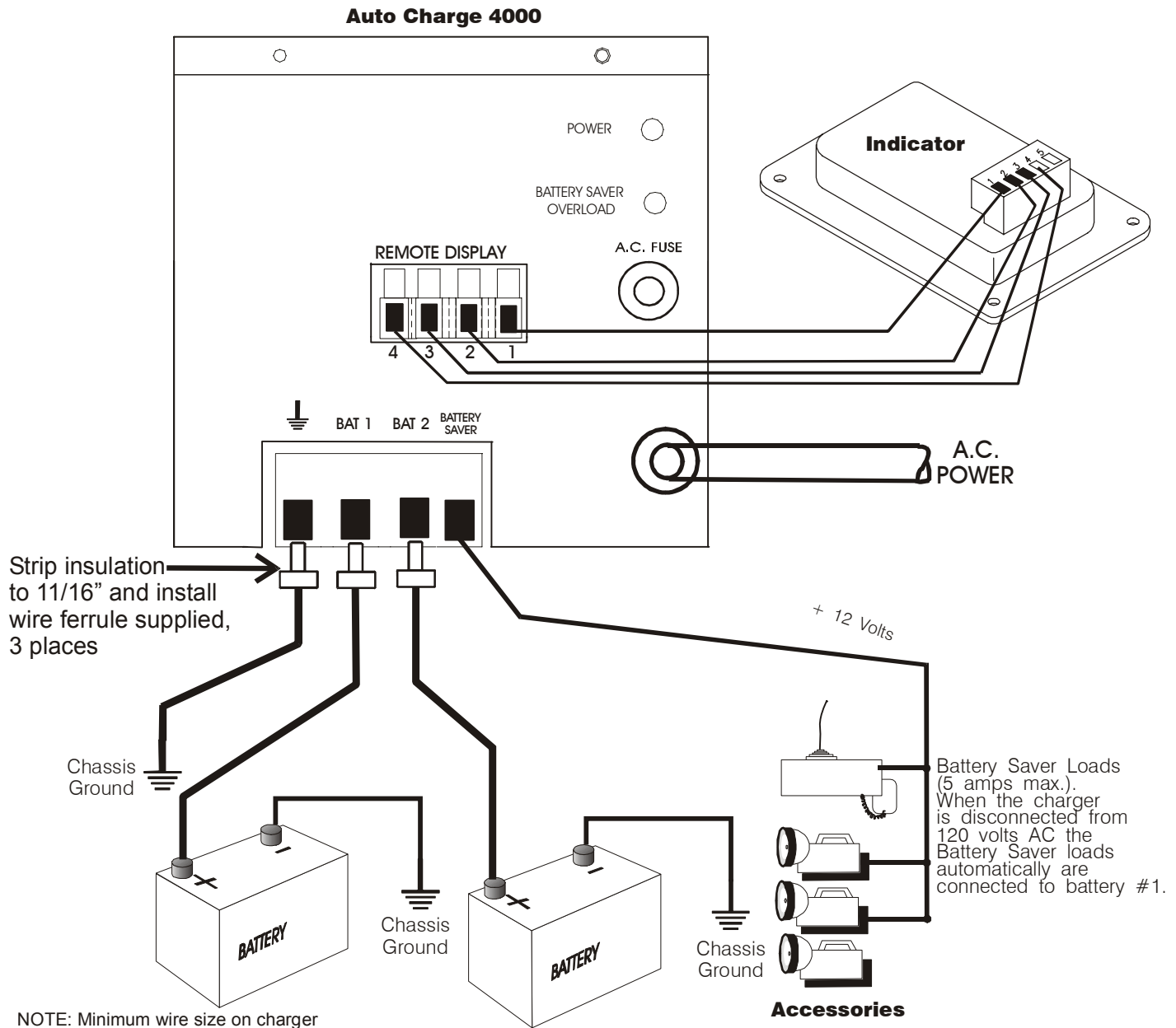

NOTE: Minimum wire size on charger output and ground is **#8 AWG**. Smaller gauge wire may cause overheating of terminal. Use 2-966067-4 wire ferrule over wire to simplify insertion of wire into terminal strip and to improve connection

Wire Chart

CONNECTION	DEFINITION	WIRE SIZE
A.C.	120 VOLTS A.C.	14 AWG
COM	GROUND LINE	8 AWG
BAT 1 / BAT 2	POSITIVE CHARGING LEAD VEHICLE BATTERY 1	8 AWG
BATTERY SAVER	POSITIVE OUTPUT	14 AWG

IMPORTANT: Wire size is for a maximum length of 10 feet. If longer, larger wiring is required.

SPECIFICATIONS

Input: 120 volt, 50/60 Hz, 8 amperes

Input Fuse: 15 amperes, fast acting

Output: 12 volts D.C. 40 amperes

Remote Sensing: Electronic, sense wires not required

Number of Charger Outputs: 2

Number of Battery Saver Outputs: 1

Battery Saver Output: 12 volts D.C., 5 amperes Max.

Indicators: Power: Red LED, indicates 120 volts power applied

Battery Saver Overload: Yellow LED, indicates Battery

Saver load greater than 5 amperes

Bar Graph: indicates charger output and condition of each battery

Weight: 24 lbs

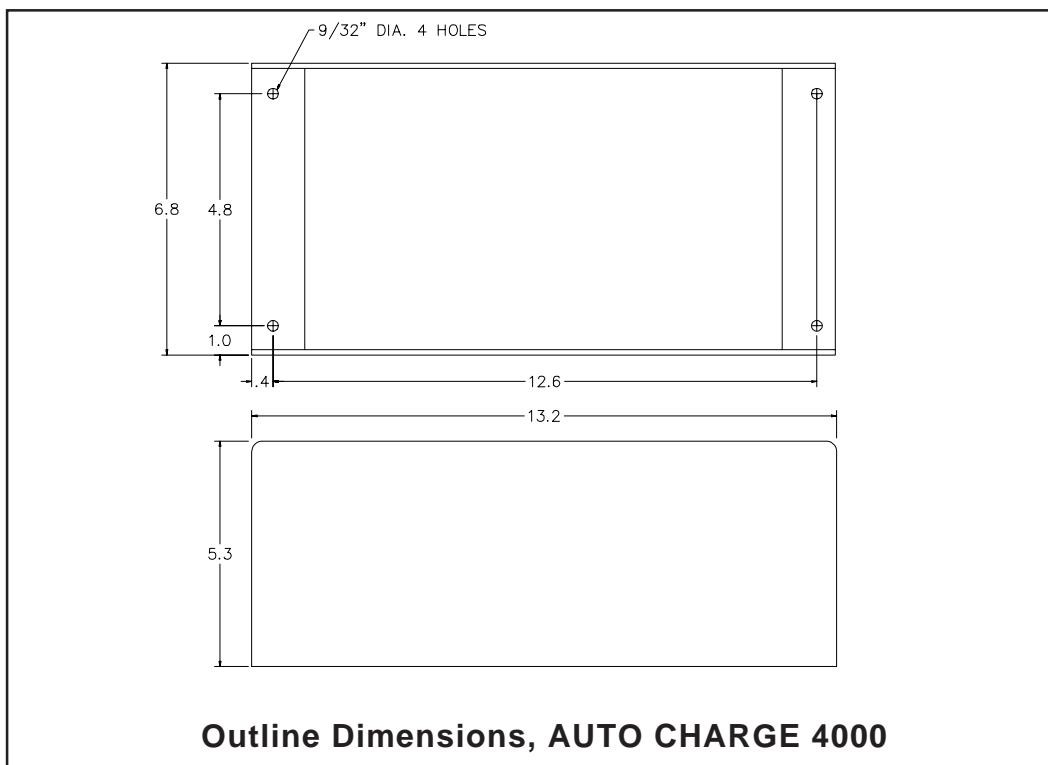

INSTALLATION RECORD & WARRANTY

Date Installed _____

Installed By _____

Vehicle Identification _____

Vehicle Owner _____

WARRANTY

All product of Kussmaul Electronics Company Inc. are warranted to be free of defects of material or workmanship. Liability is limited to repairing or replacing at our factory, without charge, any material or defects which become apparent in normal use within 3 years from the date the equipment was shipped.

Kussmaul Electronics Company, Inc. shall have no liability for damages of any kind to associated equipment arising from the installation and /or use of the Kussmaul Electronics Company, Inc. products. The purchaser, by the acceptance of the equipment, assumes all liability for any damages which may result from its installation, use or misuse, by the purchaser, his or its