

# Mobile Data Power

## Model: MDP-25



Topic	Section
Features.....	2
Operational Features Summary.....	2
Back-up Battery Power	
Internal Charger	
Voltage Spike Protection	
RF Noise Filtering	
Warning of Imminent Loss of Power	
Low Voltage Status Indicators	
Status Indicators	
Low Power Consumption Mode	
Materials Provided.....	3
Installation.....	3
Mechanical	
Power Wiring	
Signal Wiring	
Output Settings: Default and Optional	
Operation.....	4
Battery Replacement.....	5
Test/Troubleshooting.....	6
Specifications.....	6

  
**NEWMAR**<sup>®</sup>  
*DC Power Onboard*  
*Emergency & Specialty Vehicles*  
[www.newmarEVpower.com](http://www.newmarEVpower.com)

M-MDP  
As of May 10

## Features:

- Protects mobile computers against system crash preventing lengthy reboot sequences and loss of data due to:
  - Voltage dip during engine cranking.
  - Voltage drop and decay due to loading high power accessories and aging batteries.
- Provides supplemental voltage in milli-seconds to mobile computers when low vehicle battery is sensed, ensuring no interruption in power.
- Back-Up Battery maintains DC output voltage during dips and black-outs — preventing memory loss and system crashes in mission critical mobile electronics. Internal back-up battery automatically switches online when the vehicle's battery voltage reaches 10.0 VDC. Vehicle battery auto-reconnects when vehicle voltage reaches 11.5 VDC or higher.
- Internal Battery Charger
  - Built-in, 3-Stage temperature compensated battery charger maintains internal 8 Ah battery at full charge, ready to provide back up power for an extended period.
  - Noise filter eliminates electronic noise and interference, providing clean power required by mobile electronics for proper operation.
- Overvoltage transient protection prevents damage to sensitive circuitry due to voltage line spikes.
- Built-in LVD (Low Voltage Disconnect) activates when the internal back-up battery reaches 9.6VDC; protecting the internal battery from complete discharge.
- Power conserving circuitry places internal charger in sleep mode after approximately 30 minutes once charger switches to float mode. Sleep mode duration adjustable (factory default is 48 hours), then charger comes back online to charge and float battery for a minimum of 30 minutes before sleep mode is restarted. **Note:** Sleep mode is delayed if back-up mode is detected before the 30 minutes has elapsed. Once again, when charger reaches float mode the 30 minute delay starts.
- Provides output warning signals to mobile computers (such as Motorola® MW800 series work stations).
- Initiates low voltage shut down sequence in mobile computers protecting data and hard drive.
- Alerts when system is operating on battery back-up.
- Power Status indicators provide visual system operational status / troubleshooting.
- Conformal coated printed circuit board resists corrosion.
- Rugged, rust and corrosion resistant powder coated aluminum case provides protection for components.
- All components selected for dependable performance in hostile environments.
- Two year limited warranty.

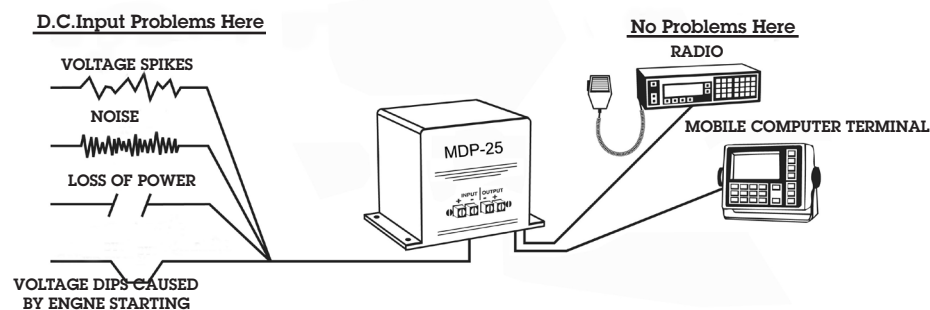

# NEWMAR®

DC Power Onboard  
Emergency & Specialty Vehicles

[www.newmarEVpower.com](http://www.newmarEVpower.com)

2

## MATERIALS PROVIDED

The MDP-25 is supplied with the following materials:

- (4) # 8 ring lugs for 8 gauge wire
- (1) Installation/Operation Manual

Check to see that these have been included with the packaging. For any missing items, please contact Factory.

## INSTALLATION

### Mechanical:

Locate a flat surface close to the power line that feeds the electronics. For best results, the MDP should be within 24" of the critical electronics. The case need not be grounded, so it is acceptable to mount the unit on wood or metal. Securely mount the unit in any orientation, however horizontal is best. **Note:** In order to ease future battery replacement, it is recommended that the front of the MDP remain un-obstructed.

### Power:

#### Input wiring:

- 1) Remove both Input and Output fuses on MDP (ATC-30 x 2) before installation. Remove terminal block cover.
- 2) Turn off the power on the input wires by disconnecting the battery or shutting off the appropriate circuit.
- 3) Identify the positive and negative lead in the power line and cut at an appropriate location. Use the lugs supplied, wire the input to the MDP – note it is recommended that the input be fused at the source, see illustration below.

#### Output wiring:

Using the table below, select the proper wire size for your installation and attach to terminal block. Four rings lugs for 8 AWG wire size are included with the MDP-25. Replace terminal block cover to prevent accidental shorting of the terminals.

AMPS*	CABLE LENGTH (feet)	
	10'	15'
0 - 10 AMPS	12 AWG	10 AWG
10 - 25 AMPS	8 AWG	8 AWG

\* Current draw of Electronics being powered.

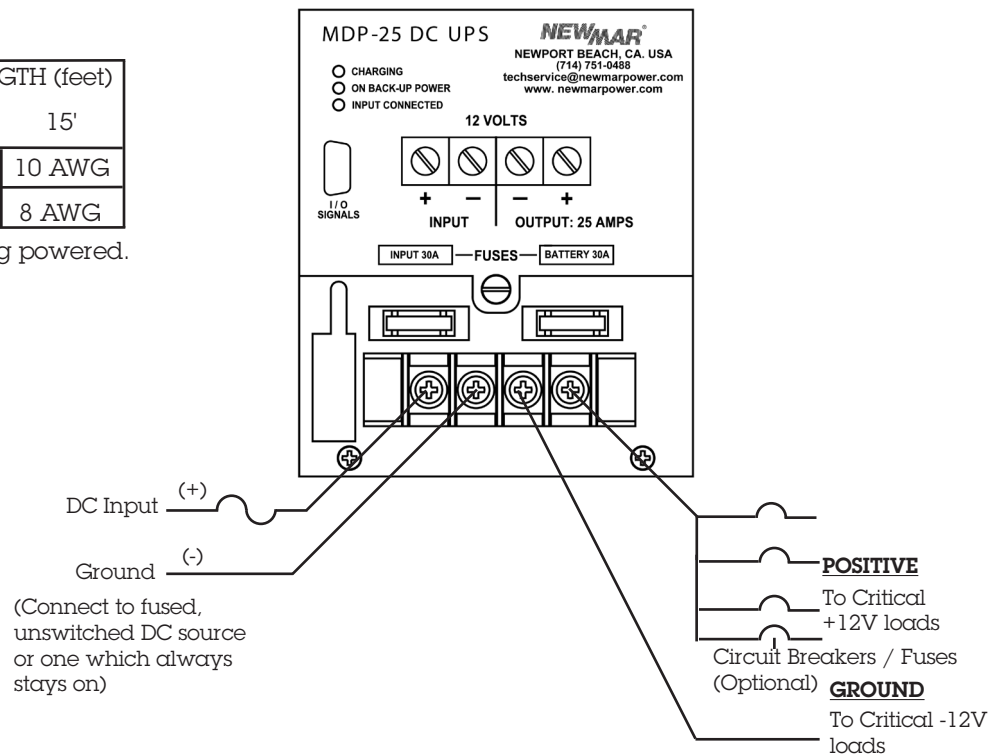

# NEWMAR®

DC Power Onboard  
Emergency & Specialty Vehicles

www.newmarEVpower.com

## Output Signals:

The MDP is programmed to provide early warning signals to mobile data computers designed for this input (such as Motorola® MW 800 Series workstations.) Interface signals for this output is located on the D-sub connector per the following pin out (please contact factory for mating connector with pigtailed):

### Signal Key:

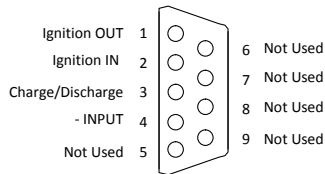

- 1) Ignition OUT - to be connected to MDC interface with signal which initiates startup and shutdown sequence of computer.
- 2) Ignition In
- 3) Charge/Discharge signal – used to signal computer that power is coming from backup battery. Active LOW (<2V)

## OPERATION

Under normal operating conditions, the electronics operate from primary battery voltage of the vehicle or vessel. This same voltage powers the internal battery charger that maintains the MDP internal battery in a fully charged state. The charger circuit operates on an input range of 9.5-14 volts, so even if the primary battery voltage decays the MDP internal battery will receive proper voltage and be maintained at full charge. The internal charger has a rapid recovery, three step output and temperature compensation sensor that varies the charge voltage based on ambient temperature to prolong battery life.

A fast acting sense circuit connects the internal battery online to the electronics any time when the input voltage drops below 10 volts or total interruption of voltage occurs augmenting voltage to the electronics for 3 seconds. If proper primary voltage is not restored within the 3 second time frame, input from the vehicle battery disconnects and electronics operate entirely from the MDP reserve battery (see settings sections for variations on this function).

The internal MDP battery will continue to supply power until primary vehicle or vessel battery voltage is restored (> 12.0 volts) or to the point where the MDP internal battery discharges below 9.6 volts, at which time a low voltage disconnect energizes, shutting off all power to the MDP output. When primary vehicle or vessel voltage is restored, the internal battery will begin to recharge and be available for reserve power after voltage is restored to >13.5 volts (approx 120 minutes from fully discharged state)

**Important Note:** The MDP function is that of an uninterruptable power source, so if electronics are wired directly to the MDP output and the primary feed voltage to the MDP is via an ignition switch, when the switch is turned off the MDP will continue to power the load until its internal battery reaches a low voltage disconnect point. Ideally the power to the MDP should be left on. If the vehicle is left for an extended period, the powered electronics should be shut off to conserve the primary battery. The MDP has a power conservation "sleep mode" that initiates and turns off the 3 stage charger when the unit senses float charge for more than 20 minutes. For long term storage, remove loads from MDP output and remove input fuse.

**CAUTION:** DO NOT LEAVE THE BATTERY DISCHARGED FOR EXTENDED PERIODS OF TIME. IT MAY BE PERMANENTLY DAMAGED AND MAY NOT TAKE A RECHARGE

## Status LEDs

Refer to the illustration below for location of the front panel status indicator lights:

1. 'CHARGING' Green LED activates when charge-mode begins or, INPUT power is applied for the first time and indicates Backup battery is being charged.
2. Amber 'ON BACK-UP POWER' LED activates when INPUT < 10 volts and indicates Back-up battery providing power to OUTPUT
3. 'INPUT CONNECTED' Green LED activates when INPUT > 10 volts and indicates INPUT is providing power to OUTPUT

**Settings:** Modifications can be made to disconnect points and timer circuits - Please contact factory.

1. Charging (Green)
2. On Back-Up Power (Amber)
3. Input Connected (Green)

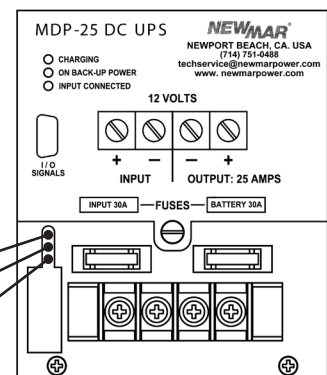

# NEWMAR®

DC Power Onboard  
Emergency & Specialty Vehicles

www.newmarEVpower.com

## INTERNAL BATTERY CHARGING & REPLACEMENT:

The MDP internal battery is rated at 8 Ah, is a sealed lead acid and requires no maintenance. Battery life is typically up to five years, but will vary depending on use and operating environment. The battery should be replaced no less frequently than every five (5) years to guarantee proper operation of the MDP. (Request part # 591-0712-0)

To determine the age of the battery, check the date code located on top of the battery. The four digits refer to the year and month of manufacture. For instance, a unit with a date code of "1035" was manufactured the 35th week of 2010.

To replace the battery first remove power to the MDP input wiring and turn off all 12 Volt loads connected to MDP. Remove the fuse from the holder labeled "BATTERY". To access the battery, loosen and back out the two top battery retaining bracket securing screws and loosen the single front panel screw. Pull the door out from the bottom which will release the top edge from the engaging pins (refer to the front panel illustration below). Note only three screws need be loosened, do not loosen / remove any other case hardware.

Once the door is removed, you will see the battery is secured in position at the top by a retaining bracket, push up on the bracket while pulling on the plastic tab and the battery will begin to slide out of the compartment. When the terminals are exposed, disconnect the push on connectors and remove the battery. **NOTE:** Ensure battery removal strap is in place behind the battery before re-installing the battery. Reinstall the new battery by pushing up on the retaining bracket and sliding the battery partially back into the compartment, re-attach the terminals (confirm proper polarity or damage can result) and push the battery all the way back in until the retaining bracket snaps into place. Dispose of the old battery properly. Re-tighten the two battery retaining bracket securing screws. Re-install the battery access door and tighten its single screw. Although the battery is sealed, it is a Lead-Acid type, so there are restrictions on its disposal.

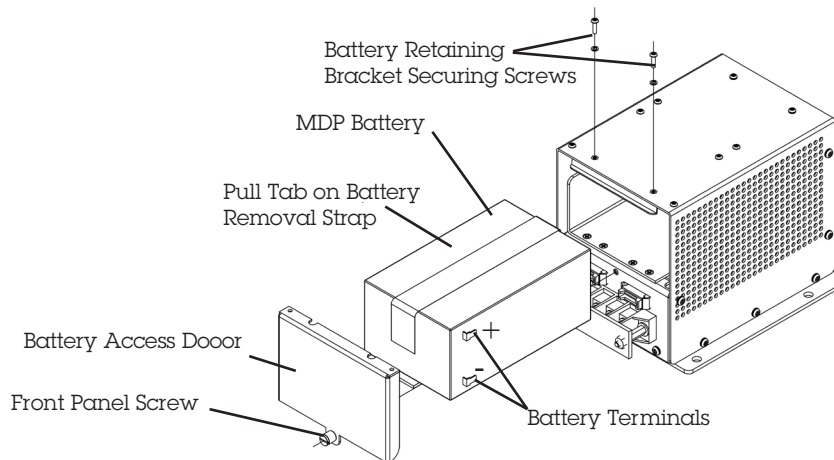

## TEST / TROUBLESHOOTING

Refer to the status LED indicator section above, which provides diagnostics of what stage the MDP is currently operating.

### 1) Testing Battery Back-up Function:

With a load connected to MDP output remove input fuse and confirm load is powered without interruption from MDP internal battery: The two GREEN LED's ("CHARGING" & "INPUT CONNECTED") should extinguish and the AMBER "Back-up Power" LED will illuminate.

### 2) Start-up:

When connecting or reconnecting input power to the MDP it is normal for the "INPUT CONNECTED" LED & "BACK-UP POWER" LED to both illuminate for 2-3 seconds.

### 3) Charging LED:

It is normal for the CHARGING LED to extinguish when the three stage charger goes in to sleep mode. (Sleep mode reduces MDP input current draw when the internal battery is full charged.)

4) If fuses blow repeatedly, this usually indicates a shorted component. Contact NEWMAR for further trouble shooting advice. Always verify that the replaced fuses are of the correct rating. Use standard ATC fuses. Do not use slow-blow fuses.

# NEWMAR®

DC Power Onboard  
Emergency & Specialty Vehicles

[www.newmarEVpower.com](http://www.newmarEVpower.com)



## FACTORY CONTACT INFORMATION

If a problem with the MDP-25 persists after you have applied the above-outlined solutions, or if you have any questions about the installation and proper operation of the MDP-25, please contact NEWMAR's Technical Services Manager:

**Phone:** 714-751-0488 - From the hours of 7:00 A.M. to 4:30 P.M. weekdays, P.S.T.

**Fax:** 714-957-1621 - Anytime

**Email:** techservice@newmarpower.com - Anytime

We are happy to consult with you to resolve any problems or questions you may have. If during consultation, it appears the MDP-25 must be returned to the factory for repair we will issue a Return Materials Authorization at that time.

## SPECIFICATIONS:

**INPUT:** Stand-by: 12 VDC, 12.2 -> 15.5 VDC, 11.5 minimum input required for start up,  
Maximum Input Current: 28.5 Amps (25 Amps max. Load + 3.5 Amps Charger)  
Stand-by Current: <40 mA (no load on output, internal battery charged, 3 Stage charger in sleep mode)

**OUTPUT:** 12 VDC Filtered, Voltage Spike Protected with Back-Up Battery 25 amps Max.

**BACK-UP POWER:** 12.0 VDC Nominal, from 8 AH internal battery:

5 amps for 60 Minutes

10 amps for twenty Minutes

25 amps for seven Minutes

(All the above assuming fully charged battery @ 25° C)

**BATTERY:** Sealed Lead Acid, Rechargeable 8.0 AH, 5 Years Typical Life - User Replaceable

**INTERNAL CHARGER:** 2 Amps max., 3 Stage, Temperature Compensated

**FILTERING:** Audio through 200 MHz

**VOLTAGE SPIKE PROTECTION:** Transient Energy Capability; 100 Joules, 4,000 amps Max

**OPERATING TEMPERATURE:** 0-50° C

**SIZE/WEIGHT:** 5.75" H x 6.0" W x 8.5" D (14.6 x 15.24 x 51.59 cm) / 9.4 lbs. (4.3 kg)

## DIMENSIONAL DRAWINGS:

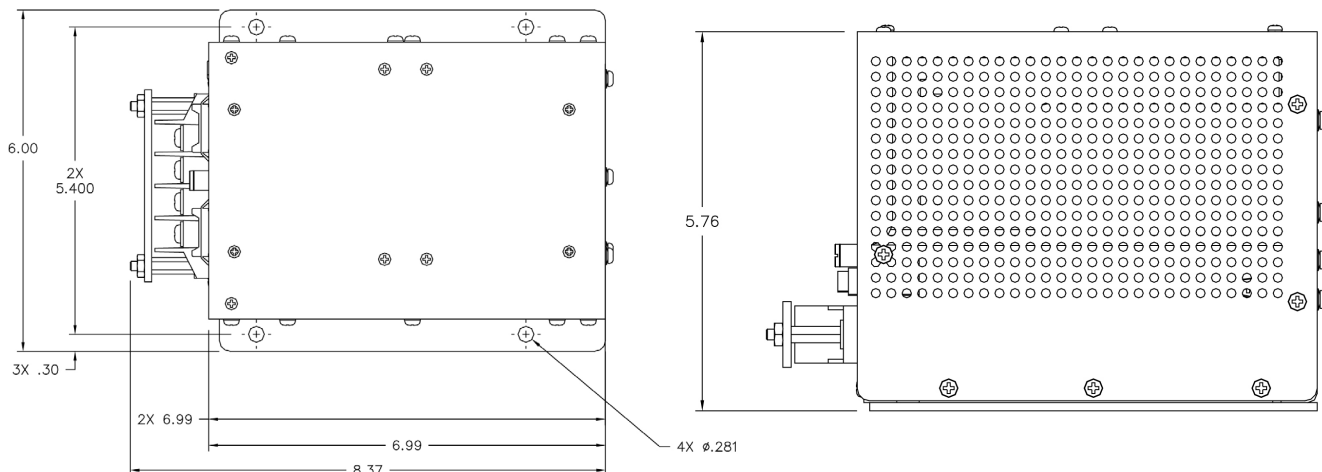

# NEWMAR®

DC Power Onboard  
Emergency & Specialty Vehicles

[www.newmarEVpower.com](http://www.newmarEVpower.com)

6